

Service Manual – Digital InterLock Coffee Grinders

Important Safeguards/Conventions

This appliance is designed for commercial use. Any servicing other than cleaning and maintenance should be performed by an authorized Wilbur Curtis service center.

- Do NOT immerse the unit in water or any other liquid
- To reduce the risk of fire or electric shock, do NOT open top panel. No user serviceable parts inside. Repair should be done only by authorized service personnel.
- Keep hands and other items away from hot parts of unit during operation.
- Never clean with scouring powders or harsh implements.

Conventions



WARNINGS – To help avoid personal injury



Important Notes/Cautions – from the factory

Models Included

- ILGD
- TL-ILGD



CAUTION: Please use this setup procedure before attempting to use this grinder. Failure to follow the instructions can result in injury or the voiding of the warranty.

QUICK START & SETUP

SETUP

1. Install the grinder on a firm, level base in a location where it can be connected to a grounded electrical outlet of 120VAC, rated at 15 amps.
2. Test the unit by running some whole bean coffee through the grinder. If any problems are encountered, refer to the troubleshooting section complete at www.wilburcurtis.com or call Technical Support at 800-995-0417.

CONNECTING THE INTERLOCK GRINDER

1. Turn both units OFF.
2. Place the grinder close enough to the brewer so it the InterLock cable will reach the brewer.
3. Locate the jack, labeled CLASS 2 WIRING ONLY, on the back of the brewer. Plug in the InterLock cable from the grinder.
4. Turn both units ON. Interlocking is complete.

INTERLOCK OPERATING INSTRUCTIONS

1. Open the door on top of the grinder and fill with fresh whole bean coffee. Close the top door.
2. Place an empty Satellite on the warmer deck of the brewer and preheat it by switching on warmer.
3. Place a new paper filter into the brewcone.
4. Insert the brewcone into the basket holder arms on the grinder.
5. Press the appropriate grind switch (SMALL, MEDIUM or LARGE).
6. Allow the grind motor to completely stop before removing the brewcone. The brew selection is now "Locked" in at the brewer and is indicated by the flashing light on the InterLock brewer.
7. Transfer the filled brewcone to the brewer and press the flashing brew button. Brew cycle is complete when the brew light stops flashing.

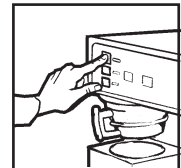
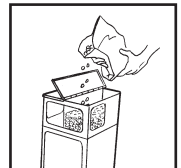
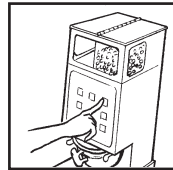

WARNING TO AVOID SCALDING. Do not remove brewcone while brew light is flashing.

ADJUSTING THE GRINDS

1. Empty hopper of coffee beans. Run grinder to clear grinding burrs of coffee.
2. Open housing cover to locate adjustment screw (8) and lock nut (7). Loosen lock nut.
3. Run motor during adjustment. Turning adjustment screw clockwise will result in a finer grind (if, while turning, you hear the grinding burrs starting to touch, immediately, back off 1/8th turn). Turning counter clockwise will produce a coarser grind.
4. With a screwdriver holding the adjustment screw in place, tighten the locknut.
5. Run some coffee beans through the machine to check the grind adjustment.
6. Replace front cover on machine.

*This adjustment may change the amount of ground coffee dispensed.

CHANGING A BROKEN SHEAR DISK

1. Unplug the power cord.
2. Empty the hopper of beans.
3. Take out the thumb screws (10) to remove the grind cap (6).
4. Pull out the grinding burr/feed worm assembly (2). The inner half of the grinding burr set will remain in the housing.
5. Separate the shear cap (5) and shear drive (3). The snapped shear disk (4) should fall out of its slot on the shear drive.
6. Inspect and clean housing (1) of any coffee or debris. Especially look for anything that may have broken the shear disk.
7. Re-insert the feed worm and grinding burr on to the motor shaft.
8. Push shear drive through burr/feed worm assembly and align large slot with tongue on the motor shaft.
9. Rotate burr/feed worm assembly to align slot with narrow slot on shear drive.
10. Insert a new shear disk into slot. Cover with the shear cap.
11. Replace grind cap and thumb screws.

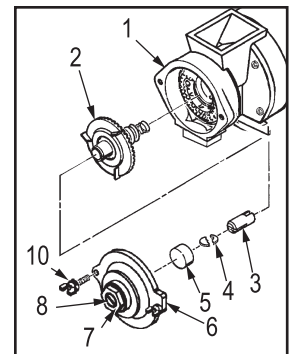

ISO 9001 REGISTERED

WILBUR CURTIS COMPANY
Montebello, CA 90640

PROGRAMMING THE GRINDER

PROGRAMMING THE ILGD & TL-ILGD GRINDER

Your grinder has been adjusted at the time of manufacture to provide satisfactory performance in most situations. If you would like to vary these settings, the grinder can be reprogrammed. Both grinders are programmed identically.

1. Place a paper filter beneath the grinder spout to catch coffee as it is ground.
2. Turn off the unit at the front panel, ON/OFF button.
3. Press and hold one of the grind buttons.
4. Press and release the ON/OFF button. Continue holding the grind button.
5. In the red window, the grind time on the button pressed will appear. Continue to hold and the time digits will start at 00 and increase. Release the button to set the new time. The table (below) can be used as a guide to estimate the amount of ground coffee you dispense with the chosen setting.
6. Wait for the motor to completely stop (10 seconds). To set and exit, press and release any other grind button.
7. Repeat the above steps to reset the other grind buttons.

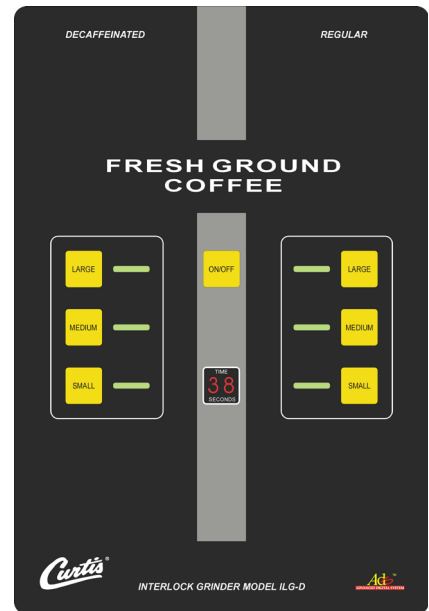

IMPORTANT NOTE: Time settings in this table are only approximate. Amounts will vary with grind texture and specific coffee bean. Weigh your output, then make adjustments as necessary.

Seconds	Ounces	Seconds	Ounces
4	1.3	15	4.5
5	1.5	20	6.2
6	1.8	25	7.6
7	2.0	30	8.8
8	2.5	35	
10	3.0	40	
12	3.7	45	

PARTS DIAGRAMS

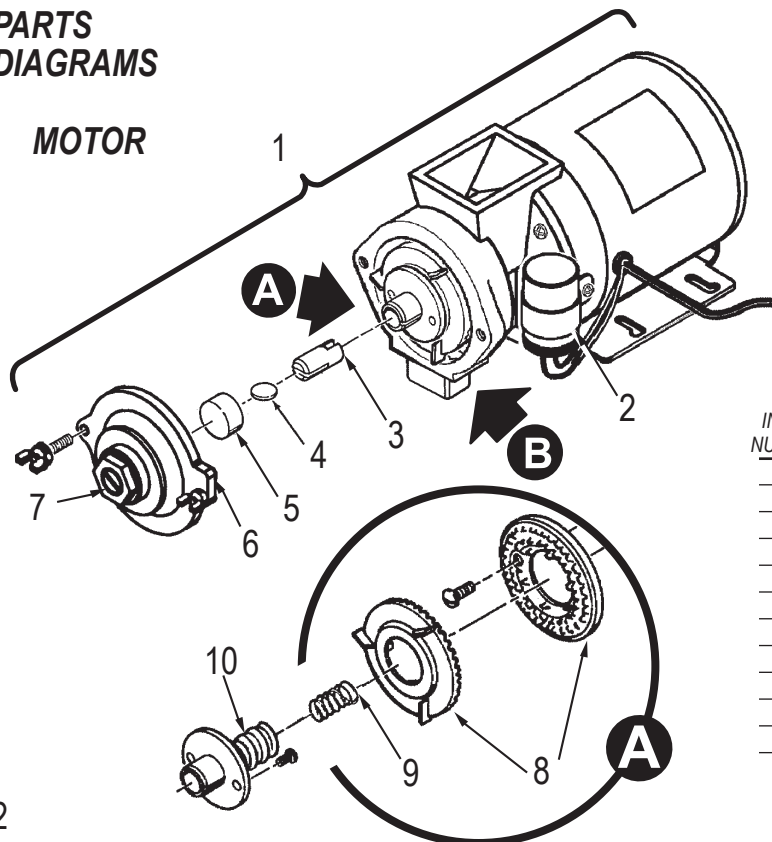

INDEX NUMBER	PART NUMBER	DESCRIPTION
1	WC-9135	MOTOR CRUSHING GRINDER ASSY 120VAC
2	WC-91026	CAPACITOR, COFFEE GRINDER ASSY
3	WC-91024	SHEAR DRIVE COFFEE GRINDER
4	WC-9107-6	SHEAR DISK, GRINDER 6 PCS
5	WC-91016	CAP, SHEAR DISK GRINDERS
6	WC-91017	COVER, GRINDER HOUSING W/LABEL
7	WC-91015	SCREW & THRUST PIN ADJUSTING ASSY
8	WC-91045	BURRS, SET CRUSH HIGH FLOW
9	WC-91021	SPRING, TENSION COFFEE GRINDER
10	WC-91020	WORM FEEDING ASSY CCG
11	WC-37283	KIT, GRINDER CHUTE NEW STYLE

PARTS DIAGRAMS

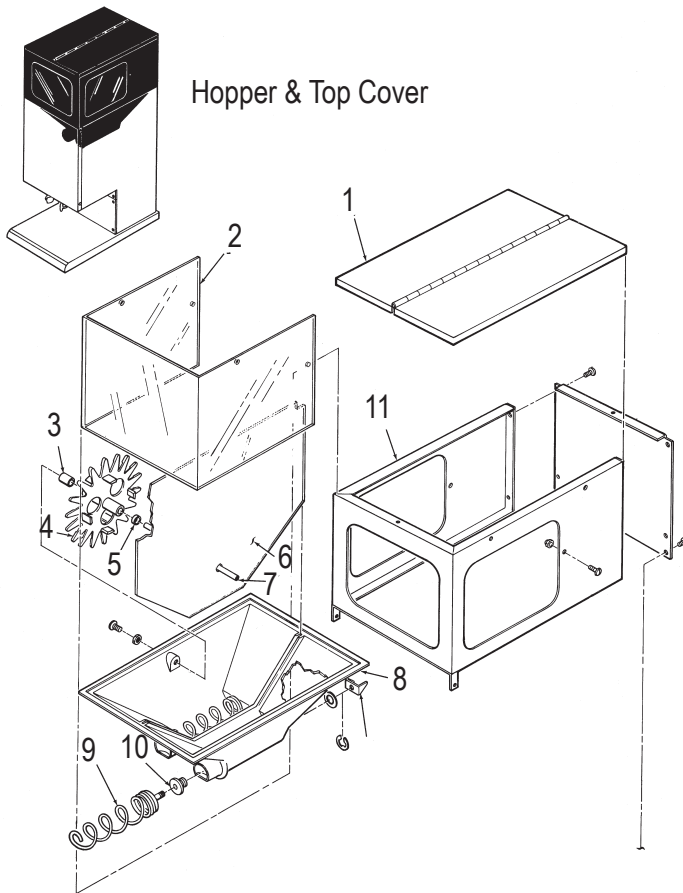

Hopper & Top Cover

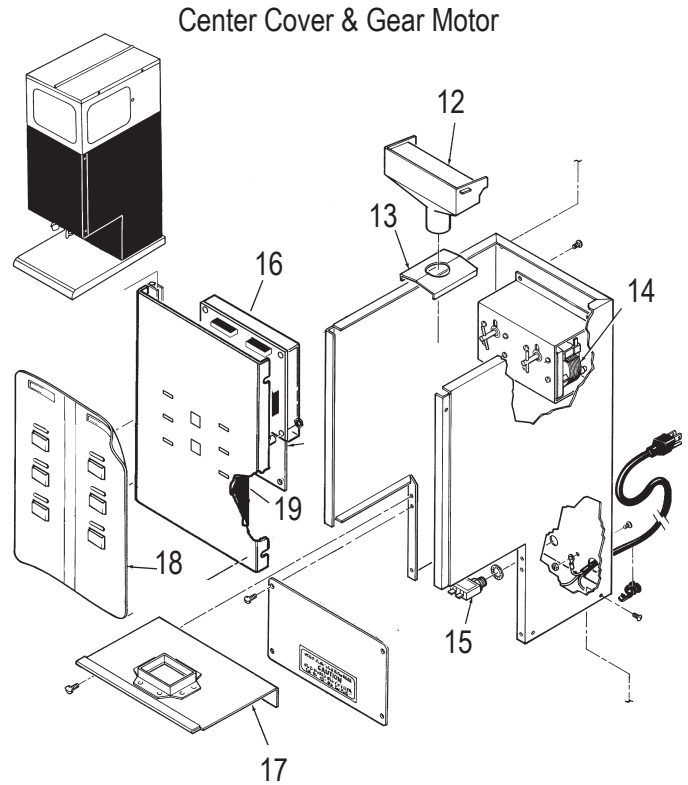

Center Cover & Gear Motor

Item	Part No.	Description
1	WC-9118	COVER, HOPPER DUAL GRINDER ASSY
2	WC-9131	WINDOW, ACRYLIC DUAL GRINDER
3	WC-9143	SPACER, 5/8" AGITATION WHEEL (OPTIONAL)
4	WC-9160	WHEEL, GRINDER AGITATION CCG (OPTIONAL)
5	WC-9144	SPACER, 9/32" AGITATION WHEEL (OPTIONAL)
6	WC-9132	DIVIDER, DUAL HOPPER, SS
6A	WC-9188	DIVIDER, W/HOLE ILG-11/DHG-11 (AS SHOWN, OPTIONAL)
7	WC-9142	SHAFT AGITATION WHEEL (OPTIONAL)
8	WC-9116	HOPPER ASSY, DUAL GRINDERS
9	WC-9158	AUGER ASSY DHG/ILG/ILGD
10	WC-9183	BEARING, AUGER BR
11	WC-91013	WRAP, DUAL HOPPER ILGD
12	WC-9130	FUNNEL, DHG/ILGD
13	WC-9134	SHEILD, HOUSING, ILGD/ILG/SHG/DHG
14	WC-9151*	MOTOR, GEAR 115V DUAL GRINDER
15	WC-1504	BREAKER, CIRCUIT 10A 120/250VAC
16	WC- 689*	CONTROL BOARD, ILGD, DHGILD
17	WC-9126	GUIDE, SPOUT W/A
17A	WC-9164	COVER ASSEMBLY, SPOUT (BREWCONE RAILS ONLY)
18	WC-39212*	MEMBRANE CONTROL PANEL, ILGD
18A	WC-39248*	MEMBRANE CONTROL PANEL, TL-ILGD
19	WC-3796	LABEL, ADJUSTMENT INFO SHG, DHG
20	WC-9107-6*	DISK, SHEAR COFFEE GRINDER 6 PCS/PKG
21	WC-37283*	KIT, GRINDER CHUTE NEW STYLE
22	WC-3503	LEG, 3/8"-16 STUD SCREW BUMPER
22A	WC-3502	LEG, SCREW BUMPER 8/32 STUD (OLDER UNITS)
23	WC-3518	LEG, GLIDE 3/8"-16 STUD SCREW
24	WC-4813	SCREW, SHOULDER, 5/16 x 5/8
25	WC-9141	BASKET HOLDER ASSY
26	WC-9135*	MOTOR, CRUSHING GRINDER ASSY 120VAC SHG/DHG/ILGD
27	WC-9155	SPRING, BASKET HOLDER
28	WC-9123	NUT, HEX ADAPTER GRINDER

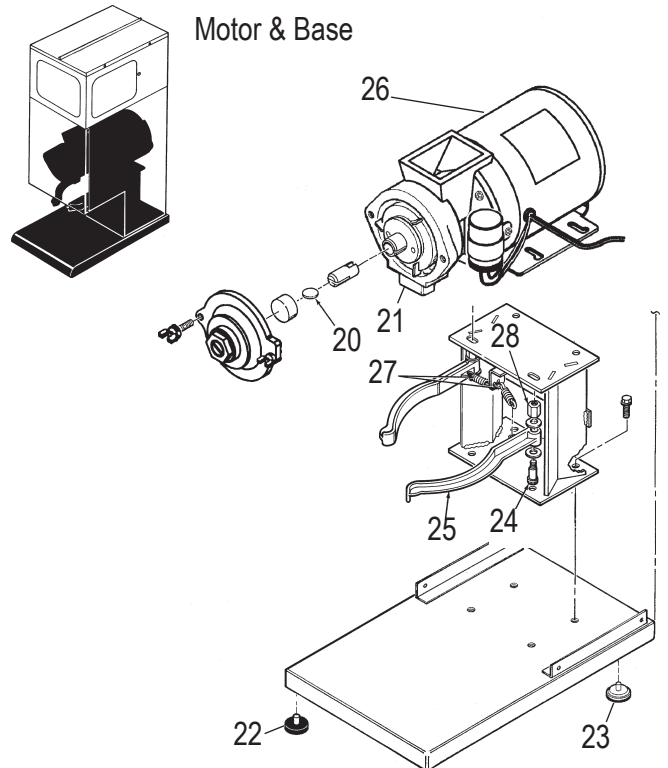

Motor & Base

* RECOMMENDED PARTS TO STOCK

ELECTRICAL SCHEMATIC

DIAGRAM NO. WD-ILGD-10	PART NO. ILGD-10 GRINDER DIGITAL INTERLOCK	WIRES 2+GND PHASE SINGLE	CYCLE 60 VOLTAGE 120	POWER 1/2 HP AMPERAGE 8	DRAWN BY MDD DATE: 3/2/2000	CHECKED: <i>A. Deuser</i> DATE: 3/2/2000	APPROVED: <i>Fred</i> DATE: 3.2.00	FOR/ECH. NO.: 3584	REV: E
---------------------------	---	-----------------------------------	-------------------------------	----------------------------------	--------------------------------------	---	---	-----------------------	-----------

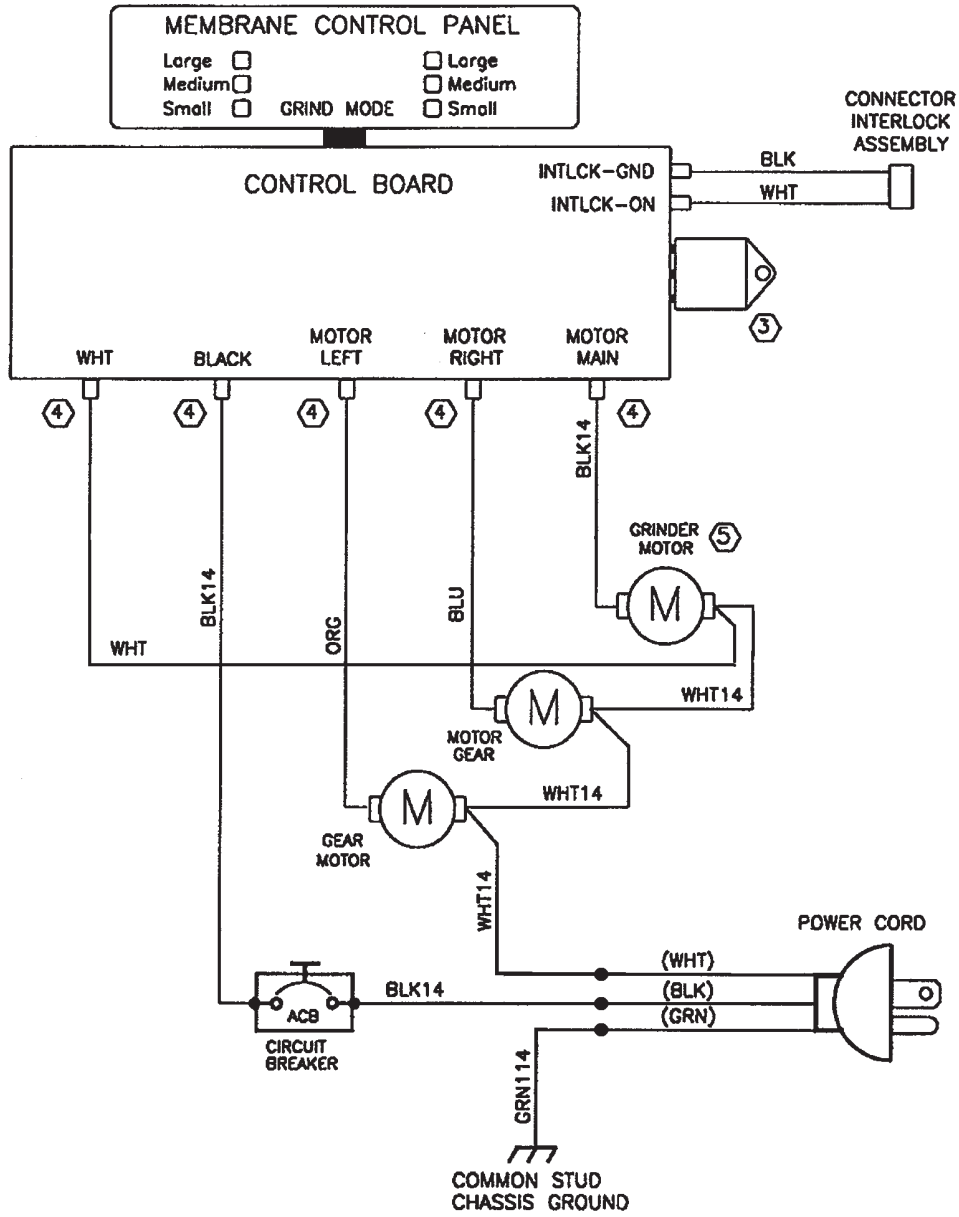

- (5) USE WC-9135 FOR PRIMARY MOTOR AND WC-9150 AS AN ALTERNATE.
- (4) WHEN APPLICABLE USE FLAG TYPE .250 QUICK DISCONNECT TERMINALS.
- (3) DO NOT OPERATE UNIT (PCBOARD) WITHOUT HEATSINKING THE TRIAC. USE HEATSINK ASSEMBLY, WC-6813.
- 2 DO NOT CHANGE NOR SUBSTITUTE WIRE COLORS.
- 1 ALL WIRES SHALL BE TEFLON PER UL1330 OR UL APPROVED APPLIANCE WIRE.

NOTE: UNLESS OTHERWISE SPECIFIED

Product Warranty Information

The Wilbur Curtis Company certifies that its products are free from defects in material and workmanship under normal use. The following limited warranties and conditions apply:

3 Years, Parts and Labor, from Original Date of Purchase on digital control boards.

2 Years, Parts, from Original Date of Purchase on all other electrical components, fittings and tubing.

1 Year, Labor, from Original Date of Purchase on all electrical components, fittings and tubing.

Additionally, the Wilbur Curtis Company warrants its Grinding Burrs for Forty (40) months from date of purchase or 40,000 pounds of coffee, whichever comes first. Stainless Steel components are warranted for two (2) years from date of purchase against leaking or pitting and replacement parts are warranted for ninety (90) days from date of purchase or for the remainder of the limited warranty period of the equipment in which the component is installed.

All in-warranty service calls must have prior authorization. For Authorization, call the Technical Support Department at 1-800-995-0417. Effective date of this policy is April 1, 2003.

Additional conditions may apply. Go to www.wilburcurtis.com to view the full product warranty information.

CONDITIONS & EXCEPTIONS

The warranty covers original equipment at time of purchase only. The Wilbur Curtis Company, Inc., assumes no responsibility for substitute replacement parts installed on Curtis equipment that have not been purchased from the Wilbur Curtis Company, Inc. The Wilbur Curtis Company will not accept any responsibility if the following conditions are not met. The warranty does not cover and is void under the following circumstances:

- 1) Improper operation of equipment: The equipment must be used for its designed and intended purpose and function.
- 2) Improper installation of equipment: This equipment must be installed by a professional technician and must comply with all local electrical, mechanical and plumbing codes.
- 3) Improper voltage: Equipment must be installed at the voltage stated on the serial plate supplied with this equipment.
- 4) Improper water supply: This includes, but is not limited to, excessive or low water pressure, and inadequate or fluctuating water flow rate.
- 5) Adjustments and cleaning: The resetting of safety thermostats and circuit breakers, programming and temperature adjustments are the responsibility of the equipment owner. The owner is responsible for proper cleaning and regular maintenance of this equipment.
- 6) Damaged in transit: Equipment damaged in transit is the responsibility of the freight company and a claim should be made with the carrier.
- 7) Abuse or neglect (including failure to periodically clean or remove lime accumulations): Manufacturer is not responsible for variation in equipment operation due to excessive lime or local water conditions. The equipment must be maintained according to the manufacturer's recommendations.
- 8) Replacement of items subject to normal use and wear: This shall include, but is not limited to, light bulbs, shear disks, "O" rings, gaskets, silicone tube, canister assemblies, whipper chambers and plates, mixing bowls, agitation assemblies and whipper propellers.
- 9) Repairs and/or Replacements are subject to our decision that the workmanship or parts were faulty and the defects showed up under normal use. All labor shall be performed during regular working hours. Overtime charges are the responsibility of the owner. Charges incurred by delays, waiting time, or operating restrictions that hinder the service technician's ability to perform service is the responsibility of the owner of the equipment. This includes institutional and correctional facilities. The Wilbur Curtis Company will allow up to 100 miles, round trip, per in-warranty service call.

RETURN MERCHANDISE AUTHORIZATION: All claims under this warranty must be submitted to the Wilbur Curtis Company Technical Support Department prior to performing any repair work or return of this equipment to the factory. All returned equipment must be repackaged properly in the original carton. No units will be accepted if they are damaged in transit due to improper packaging. **NO UNITS OR PARTS WILL BE ACCEPTED WITHOUT A RETURN MERCHANDISE AUTHORIZATION (RMA). RMA NUMBER MUST BE MARKED ON THE CARTON OR SHIPPING LABEL.** All in-warranty service calls must be performed by an authorized service agent. Call the Wilbur Curtis Technical Support Department to find an agent near you.



WILBUR CURTIS CO., INC.

6913 Acco St., Montebello, CA 90640-5403 USA

Phone: 800/421-6150 ♦ Fax: 323-837-2410

♦ Technical Support Phone: 800/995-0417 (M-F 5:30A - 4:00P PST)

♦ Web Site: www.wilburcurtis.com

♦ E-Mail: techsupport@wilburcurtis.com

FOR THE LATEST SPECIFICATION INFORMATION GO TO WWW.WILBURCURTIS.COM

Printed in U.S.A. 3/09 F-3117-S Rev A