



LIQUID COFFEE BEVERAGE DISPENSER

MODEL: CLC

Introducing the Curtis Liquid Coffee Dispenser



ITEM NO

PROJECT

DATE

FEATURES AT A GLANCE

- **Precise Flavor Control** – Accurate 4-head fixed tension roller dosing system with no adjustments necessary. Precise mix ratio every time.
- **Fully Insulated Product Cabinet** – Thermoelectric technology for optimal performance and longer cooling unit life. No compressors, no condensers, no service calls.
- **Watson Marlow Medical/Laboratory Grade Pumps** – Precise AC driven system requires no adjusting.
- **Cooler filter is removable from the front of the machine** – No tools required.
- **Dynamic In-cycle Rinse** – Prevents clogging of product tubing and mixing system.
- **No Tools Necessary** – Simple to replace peristaltic tubing.
- **Fast Flow and Rapid Dispense** – One gallon per minute.
- **Customizable Back-lit Graphic Display** – Attracts customers and increases impulse sales.
- **Multiple Applications** – Manual dispense for self-serve applications or customer programmable for portion control.
- **Eco-Friendly** – Insulated tank. Plus no CFCs or HFCs.
- **Voltages from 100 to 240 volts.**
- **G3 Digital Control Module** – Delivers precise control over water temperature, volume and timing.
- **Curtis Exclusive 3/2/1 Warranty** – 3-years electronic components, 2-years non-electronic components and 1-year labor.

G3
GENERATION
THREE

CLC

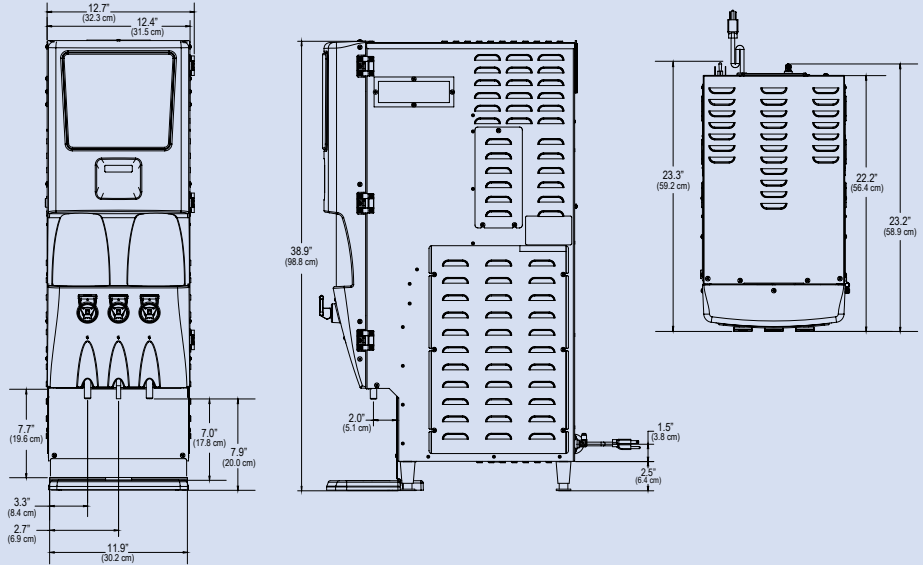

Specifications	Cup Clearance	Dimensions (H x W x D)	Product Ratio	Connector Type	Electrical Requirements	Capacity	Cord & Plug	Water Inlet	Ship Weight	Cube
CLC	7"	38.9 x 12.4 x 23.2"	25:1 - 49:1	SCHOLLE	1700/6200W 14.2/25.8A 2W+G	4.9 Gal./Hr.	6 Ft. NEMA 5-15P	1/4" Flare	125 lbs.	12.5 cu. ft.
CLCC	7"	38.9 x 12.4 x 23.2"	25:1 - 49:1	SCHOLLE	1350W 120VAC 11.3A 2W+G	3.9 Gal./Hr.	6 Ft. NEMA 5-15P	1/4" Flare	125 lbs.	12.5 cu. ft.
CLC3	7"	38.9 x 12.4 x 23.2"	50:1 - 75:1	SCHOLLE	1800W 120VAC 15A 2W+G	4.9 Gal./Hr.	6 Ft. NEMA 5-15P	1/4" Flare	125 lbs.	12.5 cu. ft.
CLC3C	7"	38.9 x 12.4 x 23.2"	50:1 - 75:1	SCHOLLE	1350W 120VAC 11.3A 2W+G	3.9 Gal./Hr.	6 Ft. NEMA 5-15P	1/4" Flare	125 lbs.	12.5 cu. ft.
CLCDV	7"	38.9 x 12.4 x 23.2"	25:1 - 49:1	SCHOLLE	6200W 240VAC 25.8A 3W+G 5200W 220VAC 23.6A 3W+G 4700W 208VAC 22.6A 3W+G 1700W 120VAC 14.2A 2W+G	20.4 Gal./Hr. 17.0 Gal./Hr. 15.3 Gal./Hr. 5.0 Gal./Hr.	No Cord Provided No Cord Provided No Cord Provided 6 Ft. NEMA 5-15P	1/4" Flare	125 lbs.	12.5 cu. ft.
CLC3DV	7"	38.9 x 12.4 x 23.2"	50:1 - 75:1	SCHOLLE	6200W 240VAC 25.8A 3W+G 5200W 220VAC 23.6A 3W+G 4700W 208VAC 22.6A 3W+G 1700W 120VAC 14.2A 2W+G	20.4 Gal./Hr. 17.0 Gal./Hr. 15.3 Gal./Hr. 5.0 Gal./Hr.	No Cord Provided No Cord Provided No Cord Provided 6 Ft. NEMA 5-15P	1/4" Flare	125 lbs.	12.5 cu. ft.

ACCESSORY ITEMS



7028000306
64 oz. Glass Decanter - Regular



70280200406
64 oz. Glass Decanter - Decaf



CLXP6401S000
64 oz. Stainless Steel Pourpot



TLXP1201S000
1.2L Stainless Steel Pour Pot



WC-8654
Scholle Connector



CSC10AV000
10" Vend Filter/Cartridge Assembly Complete



WILBUR CURTIS COMPANY, INC.
6913 Acco Street, Montebello, CA 90640-5403
Telephone: 800-421-6150 · 323-837-2300
Fax: 323-837-2406
www.wilburcurtis.com



MAY/11 - 16002 F-3690 rev. C