

# NOVA™ HEATED CABINETS



PROJECT: .....

ITEM NUMBER: .....

MODEL NUMBER: .....

## SPECIFICATIONS FOR: NW211 & NW482

- **Exterior finish:** Exterior front, sides and doors are stainless steel. The exterior top, bottom and back are galvanized steel. All exterior joints and seams fold in without lap joints. No exposed raw edges.
- **Interior finish:** Interior liner and interior door panel are stainless steel
- **Insulation:** The complete cabinet and door(s) are foamed-in-place with polyurethane insulation
- **Hardware:** Heavy duty, pivot hinges; centered key locks; horizontal work flow handles; self-adjusting magnetic gaskets; 4" diameter casters; nickel chrome shelving
- **Electrical:** All models are standard with an interior incandescent light activated by a switch for the door.
- **Instrumentation:** Digital LED thermometer reading degrees F.
- **Heating system:** Electrically operated 1500 watt heating system for the one door model and 3000 watt heating system for the two door model is controlled by a thermostat mounted in front of the cabinet. Heating element is located in the interior ducting. Forced air distribution maintains desired uniform temperature throughout the cabinet. Operating temperature is adjustable from +120°F to a maximum of +200°F.
- **Approvals:** UL, C-UL and UL Sanitation listed\*\*

## STANDARD FEATURES

- Casters (4" diameter)
- Digital thermometer
- Ducted air distribution
- Field reversible door
- Horizontal work flow handles
- Incandescent interior light
- Key locks
- Magnetic gasketing
- Nickel chrome shelves
- Operating temperature: +120°F to +200°F
- Polyurethane insulation
- Stainless steel exterior
- Stainless steel interior
- Stocked for same day shipment
- UL, C-UL & UL Sanitation listed\*\*
- Warranties: 3 year parts & labor, 5 year compressor

## OPTIONAL FEATURES

- Alarm systems
- Bun pans
- Half solid doors
- Legs in lieu of casters
- Patterned stainless steel, dent resistant doors
- Shelves (half or full door)
- Stainless steel pan slides



Nor-Lake, Inc.  
 Registered to ISO 9001:2008  
 File No. 10001816

\* Most options are available two weeks from receipt of order. Please contact us for specific questions.

\*\* C-UL is Underwriters Laboratories Safety Certification Mark which indicates that UL has tested the equipment to applicable CSA Standards.

\*\* UL Sanitation is Underwriters Laboratories Sanitation Mark which indicates that UL has tested the equipment to applicable NSF Standards.

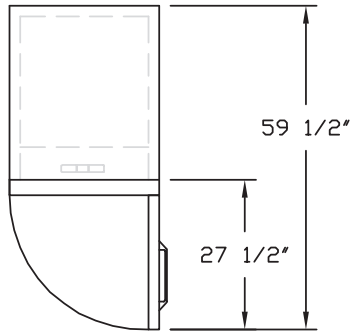

**TOP VIEW  
NW211**

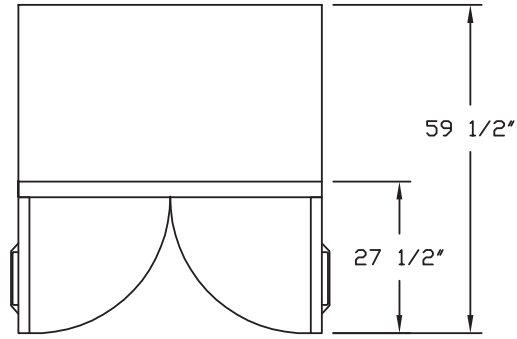

**TOP VIEW  
NW482**

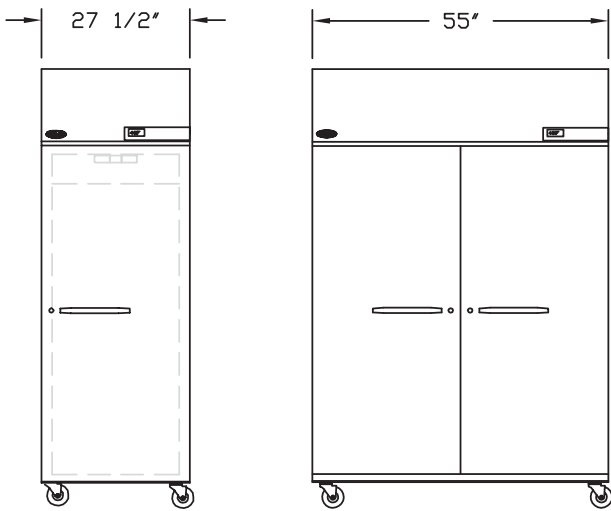

**FRONT VIEW  
NW211 NW482**

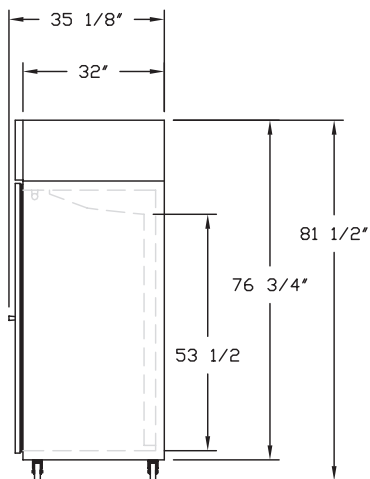

**SIDE VIEW  
BOTH MODELS**

**SPECIFICATIONS**

<b>Models</b>	<b>NW211</b>	<b>NW482</b>
<i>Crated Weight (lbs) (kg)</i>	300 (135)	545 (245)
<i>Crated Height (in) (cm)</i>	81 (203)	81 (203)
<i>Crated Width (in) (cm)</i>	31 (78)	59 (148)
<i>Crated Depth (in) (cm)</i>	38 (95)	38 (95)
<i>Interior Height (in) (cm)</i>	59 (148)	59 (148)
<i>Interior Width (in) (cm)</i>	23-1/2 (59)	51 (128)
<i>Interior Depth (in) (cm)</i>	28 (70)	28 (70)
<i>Overall Height (in) (cm)</i>	81-1/2 (204)	81-1/2 (204)
<i>Overall Width (in) (cm)</i>	27-1/2 (69)	55 (138)
<i>Overall Depth (in) (cm)</i>	35-1/8 (88)	35-1/8 (88)
<i>Gross Cubage (CuFt) (L)</i>	22.5 (637)	48.8 (1381)
<i>Number of Shelves</i>	3	6
<i>Shelf Area (SqFt) (Sqm)</i>	16.6 (1.5)	36.1 (3.3)
<i>Number of Casters</i>	4	4
<i>Heater Wattage</i>	1500	3000
<i>Electrical Characteristics</i>	115/60/1	208-230/60/1
<i>Cord &amp; Plug Furnished</i>	Yes	Yes
<i>NEMA Plug Configuration</i>	5-20P	L14-20P
<i>Total Amp Draw</i>	12.5	13.7

*Specifications subject to change without notice*



Revision Date: 03/16  
 © 2016 NOR-LAKE, INC.  
 Printed in the U.S.A.  
 Part Number: 101386