



JOB:
ITEM:
QTY:



TWO TIER BUS TUB WALL SHELF

Heavy-duty all welded aluminum construction. The heavy-duty tubular design is a perfect fit for accommodating bus tubs. Heavy-duty angle on top and bottom for easy installation and rigid design.

SHELVES AND FRAME

Each shelf is constructed of 2 1/4" x 1 1/4" x .100" T-Bar. The frame is constructed of 1 1/2" x 1 1/2" x .070" tube.



Model #98272



Phone: 800-255-0104
Fax: 877-877-7687
www.newageindustrial.com
sales@newageindustrial.com

New Age Industrial reserves the right to modify or make changes at any time without notice to materials and specifications.

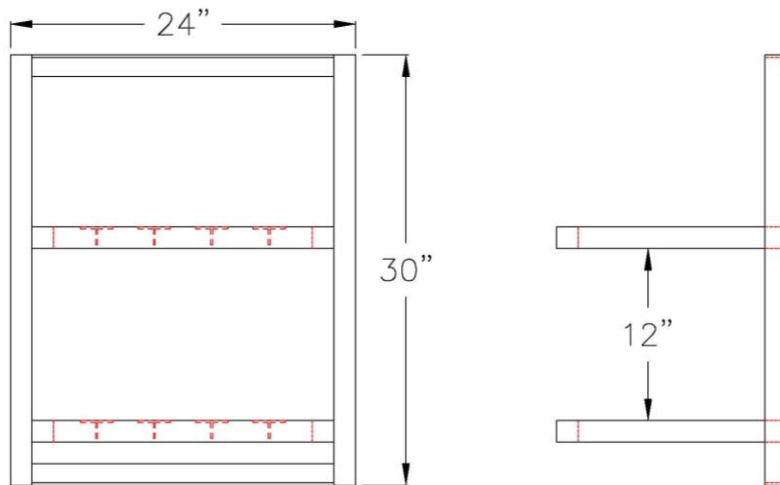

Model #98272

Model No.	Size-W	Size-H	Size-D	Number of Tiers
98142	60"	30"	16"	2
98213	48"	30"	16"	2
98272	24"	30"	16"	2
98301	36"	30"	16"	2



Phone: 800-255-0104
 Fax: 877-877-7687
www.newageindustrial.com
sales@newageindustrial.com

New Age Industrial reserves the right to modify or make changes at any time without notice to materials and specifications.