



JOB:
ITEM:
QTY:



Made in the USA

ROOM SERVICE TRAY RETURN CART

APPLICATION:

Designed to hold a high capacity of 15x20 trays. Comes with a special "staph check" cover to help protect contents.

MATERIAL:

Framework is constructed of 1"x1"x.070" wall tubing. Angle runners are 1 1/4"x1 5/8"x.100" wall. This rack comes equipped with a pan stop and vertical bumpers.

CASTERS:

This rack comes equipped with four 5" stem casters. Uprights are reinforced with a channel to help prevent breakage.

GUARANTEE:

This rack carries a **Lifetime Guarantee** against rust and corrosion and also carries a **Five-Year Guarantee** against workmanship and material defects.



Model #96004C



Phone: 800-255-0104
Fax: 877-877-7687
www.newageindustrial.com
sales@newageindustrial.com

New Age Industrial reserves the right to modify or make changes at any time without notice to materials and specifications.

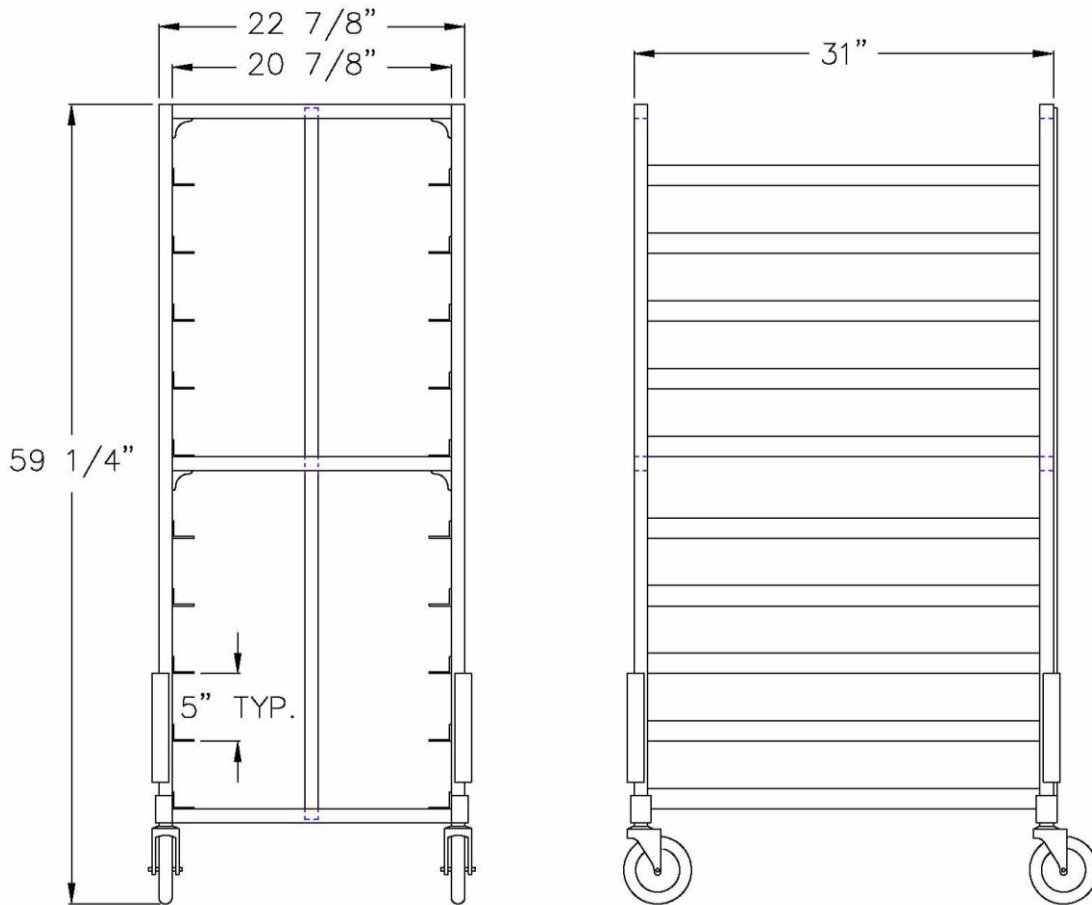

Model #96004

Model No.	Size-W	Size-H	Size-D	Runner Spac.	Pan Cap.
96004C	24"	59 1/4"	32"	5"	20



Phone: 800-255-0104
 Fax: 877-877-7687
www.newageindustrial.com
sales@newageindustrial.com

New Age Industrial reserves the right to modify or make changes at any time without notice to materials and specifications.