



JOB:  
ITEM:  
QTY:



## CARRIER CART

### APPLICATION:

This multipurpose cart for storage and transport of food modules, boxes, pots and pans, wire baskets, and similar items. All three shelves have three lips up with front lip down. The upper two shelves are slanted 1° toward the rear to facilitate drainage.

### MATERIAL:

The shelves are constructed of .080" sheet and reinforced with a 1 1/2"x1 1/2"x.070" wall tubing framework. The heavy-duty base is constructed of 1 1/2"x2 3/4"x.070" wall tubing for extra strength.

### CASTERS:

This cart comes equipped with four heavy-duty 6"x2" platform type swivel casters, two with brake.

### GUARANTEE:

This rack carries a **Lifetime Guarantee** against rust and corrosion and also carries a **Five-Year Guarantee** against workmanship and material defects.



**Model #95667**



Phone: 800-255-0104  
Fax: 877-877-7687  
[www.newageindustrial.com](http://www.newageindustrial.com)  
[sales@newageindustrial.com](mailto:sales@newageindustrial.com)

New Age Industrial reserves the right to modify or make changes at any time without notice to materials and specifications.

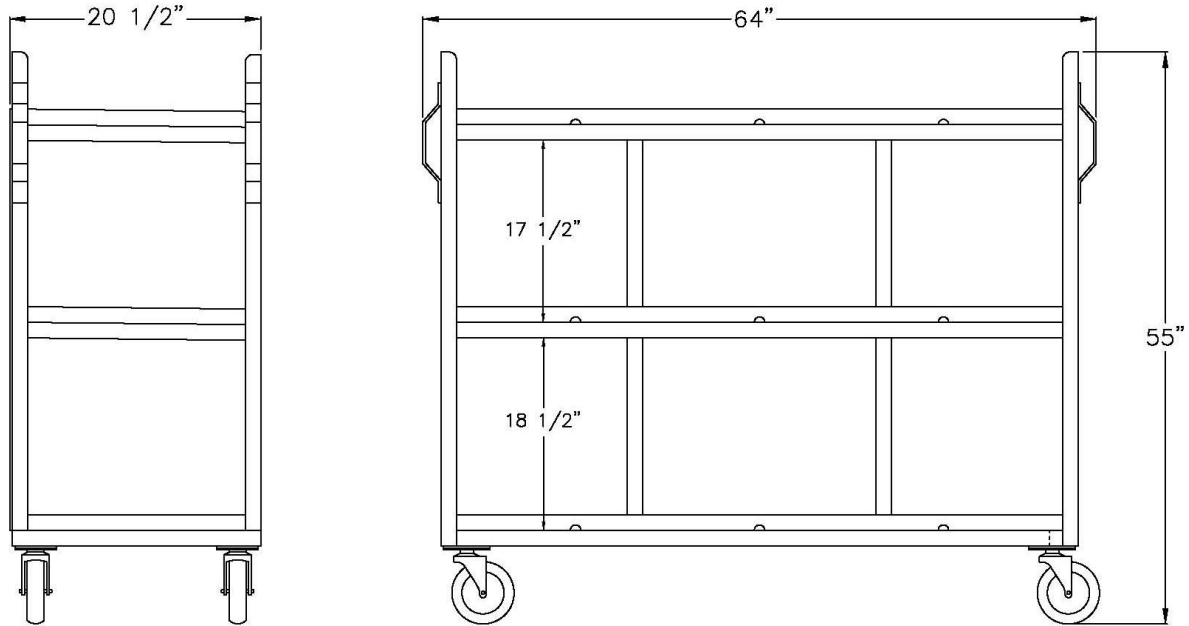

**Model #95667**

Model No.	Size-W	Size-H	Size-D	Shelf Size	No. Shelves
95667	20 1/2"	55"	64"	20"x60"	3



Phone: 800-255-0104  
 Fax: 877-877-7687  
[www.newageindustrial.com](http://www.newageindustrial.com)  
[sales@newageindustrial.com](mailto:sales@newageindustrial.com)

New Age Industrial reserves the right to modify or make changes at any time without notice to materials and specifications.