



JOB:  
ITEM:  
QTY:



## MIXER BOWL DOLLY

### APPLICATION:

Designed to make rolling heavy mixing bowls in and out of place an easy task, this rust proof unit is ideal for the kitchen/prep room atmosphere.

### MATERIAL:

The frame is constructed of 1 1/2" square tube with four 1 1/2" square tubing legs welded to a 1/4" x 3" strap to hold the bowl in place.

### CASTERS:

These dollies come equipped with four 5" platform type swivel casters to add to the rigid design of these models.

### GUARANTEE:

This dolly carries a **Lifetime Guarantee** against rust and corrosion and also a **Five-Year Guarantee** against material defects and workmanship.



Model #95636



Phone: 800-255-0104  
Fax: 877-877-7687  
[www.newageindustrial.com](http://www.newageindustrial.com)  
[sales@newageindustrial.com](mailto:sales@newageindustrial.com)

New Age Industrial reserves the right to modify or make changes at any time without notice to materials and specifications.

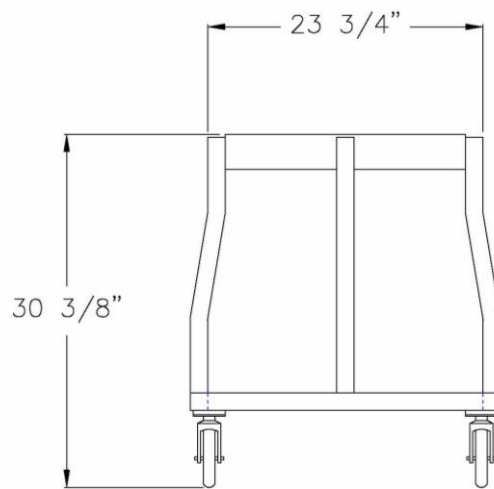
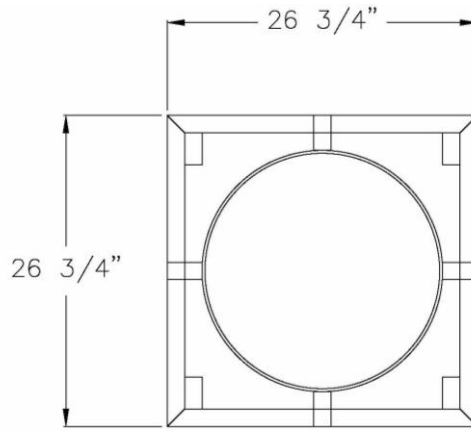

**Model #95636**

Model No.	Size-W	Size-H	Size-D	Ring Dia.
95636	26 3/4"	30 3/8"	26 3/4"	20 1/4" I.D.
98736	24 3/4"	30 3/8"	24 3/4"	18 1/4" I.D.
98737	29 3/8"	30 3/8"	29 3/8"	22 7/8" I.D.



Phone: 800-255-0104  
 Fax: 877-877-7687  
[www.newageindustrial.com](http://www.newageindustrial.com)  
[sales@newageindustrial.com](mailto:sales@newageindustrial.com)

New Age Industrial reserves the right to modify or make changes at any time without notice to materials and specifications.