



Project: _____
 Location: _____
 Item #: _____ Quantity: _____
 Model #: _____

MODEL: VAR 1500 H **DISPLAY CASES – Gelato Curved Glass**



VAR 1500 H

General Strengths

- ✓ **Sanitation.** The interior cabinet is built with rounded corners (extensive radius for easy cleaning). Quick ability to take off shelves and slides for interior cleaning. Each cabinet has a drain at the bottom of the unit. When cleaning the unit make sure the drain hose is routed to a floor drain.
- ✓ **Control systems.** Higher precision in managing temperature settings. Greater ability to adjust temperature ranges as per the end user's requirement.
- ✓ **Modular Line.** Closed and open angles to adapt the elements to a determined space. Designed for gelatos.
- ✓ **100% Tested.** All condenser units are tested 100%, in helium chambers to refrigerant leak detections.
- ✓ **Certified.** Audited and Certified by **INTERTEK** for compliance with UL 471 and NSF 7. AENOR audited and certified by internationally recognized firm. ISO 9001:2008 (Quality); ISO 14001:2004 (Environmental); OSHAS 18001:2007 (Prevention and Worker Safety)
- ✓ **Lighting.** Interior cabinet includes LED lighting, for brighter lighting and energy efficiency. LED saves 90% more energy compared to traditional fluorescent bulbs. Increases product visibility considerably.

MODELS	Dimensions (inches) (mm)			Nº Pans	Ref.	Ref. Weight (Lbs.) (gr.)	Temp. Range (°F) (°C)	Capacity (Cu. Ft.) (L)	Cond. Unit. H.P.	Case Amps	Crated Weight (Lbs.) (Kg.)
	W	D	H								
VAR 1500 H	59-7/8 1445	45 1160	55-3/8 1400	16	R404A	1.0 + 1.21 450 + 550	-5°F/+5°F -18°C/-15°C	3.95 112	1+1/2	6.1 (230V) 5.4 (115V)	660 300

ETL LISTED TO UL471 STANDARD AND SANITATION CLASSIFIED TO NSF7 – WE RESERVE THE RIGHT TO CHANGE SPECIFICATIONS WITHOUT PRIOR NOTICE



Infrico USA Corp.
 3325 N.W. 70th Avenue
 Miami, FL 33122-1332
 1.305.777.9599 Office
 1.305.777.9598 Fax

www.infrico.us
 operations@infrico.com
 service@infrico.com
 sales@infrico.com

APPROVALS: AVAILABLE AT:

Revision: 03 Date: 10/10/2013



Project: _____
 Location: _____
 Item #: _____ Quantity: _____
 Model #: _____

MODEL: VAR 1500 H **DISPLAY CASES – Gelato Curved Glass**

STANDARD FEATURES

➤ **Exterior**

- Laminated plate.
- ABS thermoformed sides.
- Compac worktop.
- Lifiable curved tempered glass.
- Night curtain standard in the back.
- Decoration standard: White or Black.



➤ **Pans**

- (16) Stainless Steel pans. Pans included.
- Dimensions: 14-1/5"x6-1/5"x6" (360x165x170 mm).

➤ **Interior**

- AISI 304 Stainless Steel.
- Structure for glasses support of silver anodized Aluminium.
- LED Lighting.

➤ **Refrigeration**

- Temperature and defrost regulated by a digital controller.
- Ventilated condensation system.
- Evaporative pan – Stainless Steel.
- Evaporator coil coated with anti-corrosion material.
- Recommendation: Case engineered to operate at 75°F and 60% RH.

➤ **Insulation**

- High density CFC free Polyurethane foam.

➤ **Electrical**

- Cord included.
- Electrical connection is 115V / 1ph / 60 Hz (digital control).
- Electrical connection is 230V / 1ph / 60 Hz (compressor).

OPTIONAL FEATURES

- ✓ Electrical connection is 220-230 V / 1ph / 50 Hz (plug type varies).
- ✓ Decoration: Red / Blue / Orange / Green.
- ✓ Customizable decoration for lower front and side panels.

➤ **ETL Listed to UL471 Standard and Sanitation classified to NSF7.**

PLAN VIEW

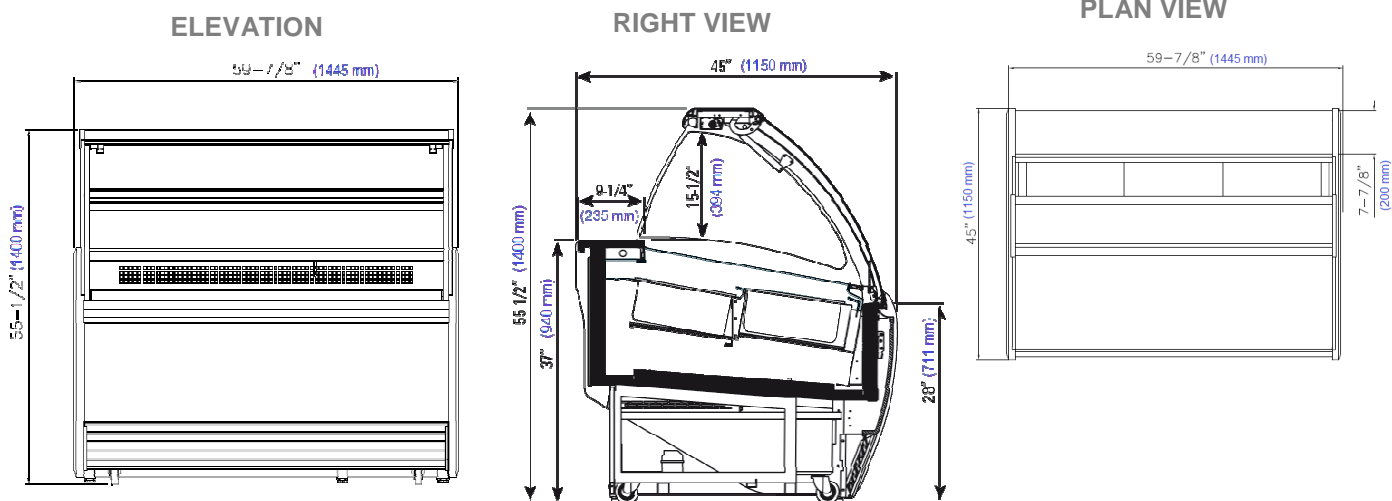

ETL LISTED TO UL471 STANDARD AND SANITATION CLASSIFIED TO NSF7 – WE RESERVE THE RIGHT TO CHANGE SPECIFICATIONS WITHOUT PRIOR NOTICE



Infrico USA Corp.
 3325 N.W. 70th Avenue
 Miami, FL 33122-1332
 1.305.777.9599 Office
 1.305.777.9598 Fax

www.infrico.us
operations@infrico.com
service@infrico.com
sales@infrico.com

APPROVALS: AVAILABLE AT:

Revision: 03 Date: 10/10/2013