



Project: \_\_\_\_\_  
 Location: \_\_\_\_\_  
 Item #: \_\_\_\_\_ Quantity: \_\_\_\_\_  
 Model #: \_\_\_\_\_

**MODEL: UC 60 P** **UNDERCOUNTER:**  
**Sandwich / Salad Prep Tables (Solid Doors)**



UC 60 P

**General Strengths**

- ✓ **Sanitation.** The interior cabinet is built with rounded corners (extensive radius for easy cleaning). Quick ability to take off shelves and slides for interior cleaning. Each cabinet has a drain at the bottom of the unit. When cleaning the unit make sure the drain hose is routed to a floor drain.
- ✓ **Doors & Drawers.** Self-closing door system with permanent pressure. Stay open feature included when door remains open after 95 degrees. All doors and drawers include triple chamber door gaskets, easy to remove and snap in. Doors are field reversible.
- ✓ **Control systems.** Higher precision in managing temperature settings. Greater ability to adjust temperature ranges as per the end user's requirement.
- ✓ **100% Tested.** All condenser units are tested 100%, in helium chambers to refrigerant leak detections.
- ✓ **Certified.** Audited and Certified by **INTERTEK** for compliance with UL 471 and NSF 7. AENOR audited and certified by internationally recognized firm. ISO 9001:2008 (Quality); ISO 14001:2004 (Environmental); OSHAS 18001:2007 (Prevention and Worker Safety)

MODELS	Dimensions (inches) (mm)			Nº Doors/Pans	Nº Shelves	Ref.	Ref. Weight (Lbs.) (gr.)	Temp. Range (°F) (°C)	Capacity (Cu. Ft.) (L)	Cond. Unit. H.P.	Case Amps 115 V.	Crated Weight (Lbs.) (Kg.)
	W	D	H									
UC 60 P	60-3/8 1533	30-1/8 765	46-1/4 1175	2 / 16	4	R134a	0.61 280	33°F/38°F 0°C/4°C	17 481	1/3	5.9	430 195

ETL LISTED TO UL471 STANDARD AND SANITATION CLASSIFIED TO NSF7 - WE RESERVE THE RIGHT TO CHANGE SPECIFICATIONS WITHOUT PRIOR NOTICE



**Infrico USA Corp.**  
 3325 N.W. 70th Avenue  
 Miami, FL 33122-1332  
 1.305.777.9599 Office  
 1.305.777.9598 Fax

**www.infrico.us**  
 operations@infrico.com  
 service@infrico.com  
 sales@infrico.com

**APPROVALS: AVAILABLE AT:**

Revision: 03 Date: 10/08/2013



Project: \_\_\_\_\_  
Location: \_\_\_\_\_  
Item #: \_\_\_\_\_ Quantity: \_\_\_\_\_  
Model #: \_\_\_\_\_

**MODEL: UC 60 P** **UNDERCOUNTER:**  
**Sandwich / Salad Prep Tables (Solid Doors)**

**STANDARD FEATURES**

- **Exterior**
  - AISI 304 Stainless Steel Top.
  - Front and sides AISI 430 Stainless Steel.
  - Completely injected compact structure.
- **Interior**
  - AISI 430 Stainless Steel.
- **Doors**
  - Self closing with stay open feature.
  - Integrated door handles.
  - AISI 430 Stainless Steel covered hinges.
  - Triple chamber snap-in door gaskets for easy removal.
  - Field Reversible.
  - Full-height door opening: 25-5/8"x21-7/8" (650x555) (mm).
- **Casters**
  - 4" diameter casters.
  - Locks provided on front set.

**OPTIONAL FEATURES**

- ✓ Set of 6" legs, height adjustable from 5" to 8".
- ✓ Set of 2" diameter casters, with lock provided on front set.
- ✓ Single Overshelves kit.
- ✓ Double Overshelves kit.
- ✓ Electrical connection is 220-230 V / 1ph / 50 Hz (plug type varies).

- **Insulation**
  - High density CFC free Polyurethane foam.
- **Salad Top**
  - AISI 430 Stainless Steel insulated lid.
  - Top includes 1/6 size polycarbonate food pans, (16) pans.
  - Pan divider bars available for varying size pan configurations.
  - Removable sanitary polyethylene cutting board included.
- **Shelving**
  - (2) Plastic coated wire shelves per door.
  - Set of Stainless Steel shelf brackets.
  - Easy remove for cleaning
  - Dimensions WxD: 27-1/4"x17" (692x432) (mm).
- **Refrigeration**
  - Front-breathing refrigeration system.
  - Temperature regulated by thermostatic control.
  - Evaporative pan.
  - Evaporator coil coated with anti-corrosion material.

- **Electrical**
  - Cord and NEMA 5-15P plug. 
  - Electrical connection is 115V / 1ph / 60 Hz.
- **ETL Listed to UL471 Standard and Sanitation classified to NSF7.**

**PLAN VIEW**

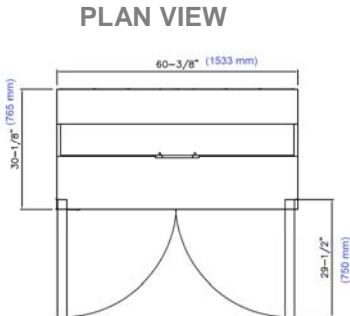
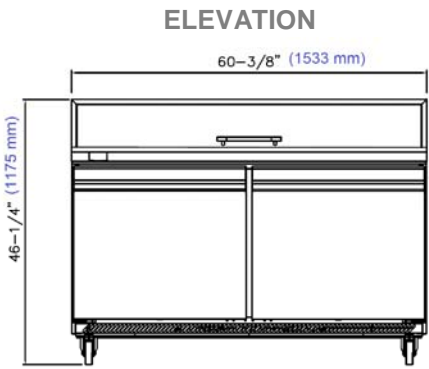

ETL LISTED TO UL471 STANDARD AND SANITATION CLASSIFIED TO NSF7 - WE RESERVE THE RIGHT TO CHANGE SPECIFICATIONS WITHOUT PRIOR NOTICE



**Infrico USA Corp.**  
3325 N.W. 70th Avenue  
Miami, FL 33122-1332  
1.305.777.9599 Office  
1.305.777.9598 Fax

**www.infrico.us**  
operations@infrico.com  
service@infrico.com  
sales@infrico.com

**APPROVALS: AVAILABLE AT:**

Revision: 03 Date: 10/08/2013