



Instruction Manual

Bucket Oil Pump

Model No. 2114E, 2114ED







GOLD MEDAL[®] PRODUCTS CO.



10700 Medallion Drive, Cincinnati, Ohio 45241-4807 USA







SAFETY PRECAUTIONS

	 DANGER
	<p>Machine must be properly grounded to prevent electrical shock to personnel. Failure to do so could result in serious injury, or death. DO NOT immerse any part of this equipment in water. DO NOT use excessive water when cleaning. Keep cord and plug off the ground and away from moisture. Always unplug the equipment before cleaning or servicing. Make sure all machine switches are in the OFF position before plugging the equipment into the receptacle.</p> <p style="text-align: right; font-size: small;">008_051514</p>

	 DANGER
	<p>Improper installation, adjustment, alteration, service, or maintenance can cause property damage, injury, or death. Any alterations to this equipment will void the warranty and may cause a dangerous condition. This appliance is not intended to be operated by means of an external timer or separate remote-control system. NEVER make alterations to this equipment. Read the Installation, Operating, and Maintenance Instructions thoroughly before installing, servicing, or operating this equipment.</p> <p style="text-align: right; font-size: small;">014_020416</p>

	 WARNING
	<p>To avoid burns, DO NOT touch heated surfaces. DO NOT place or leave objects in contact with heated surfaces.</p> <p style="text-align: right; font-size: small;">009_092414</p>

	 WARNING
	<p>ALWAYS wear safety glasses when servicing this equipment.</p> <p style="text-align: right; font-size: small;">010_010914</p>

	 WARNING
	<p>No user serviceable parts inside. Refer servicing to qualified service personnel.</p> <p style="text-align: right; font-size: small;">011_051514</p>

	 WARNING
	<p>Read and understand operator's manual and all other safety instructions before using this equipment. To order copies of the operator's manual go to gmpopcorn.com or write to Gold Medal Products Co., 10700 Medallion Drive, Cincinnati, OH 45241 USA 1-(800)-543-0862</p> <p style="text-align: right; font-size: small;">022_060215</p>



SAFETY PRECAUTIONS (continued)

	WARNING
	<p>DO NOT allow direct contact of this equipment by the public when used in food service locations. Only personnel trained and experienced in the equipment operation may operate this equipment. Carefully read all instructions before operation.</p> <p style="text-align: right; font-size: small;">012_010914</p>

	WARNING
	<p>This machine is NOT to be operated by minors.</p> <p style="text-align: right; font-size: small;">007_010914</p>

Note: Improvements are always being made to Gold Medal’s equipment. This information may not be the latest available for your purposes. It is critical that you call Gold Medal’s Technical Service Department at 1-800-543-0862 for any questions about your machine operations, replacement parts, or any service questions. (Gold Medal Products Co. does not assume any liability for injury due to careless handling and/or reckless operation of this equipment.) General images may be used in manual for reference only.

INSTALLATION INSTRUCTIONS

Inspection of Shipment

After unpacking, check thoroughly for any damage which may have occurred in transit. Claims should be filed immediately with the transportation company. The warranty does not cover damage that occurs in transit, or damage caused by abuse, or consequential damage due to the operation of this machine, since it is beyond our control (reference warranty in back of manual).

Manual

Read and understand the operator's manual and all other safety instructions before using this equipment. To order copies of the operator's manual go to gmpopcorn.com or write to Gold Medal Products Co., 10700 Medallion Drive, Cincinnati, OH 45241 USA 1-(800)-543-0862.

Model Description

2114E: Bucket Oil Pump; features a Teach Timer.

2114ED: Bucket Oil Pump; features a Dual Teach Timer.

Items Included with this Unit

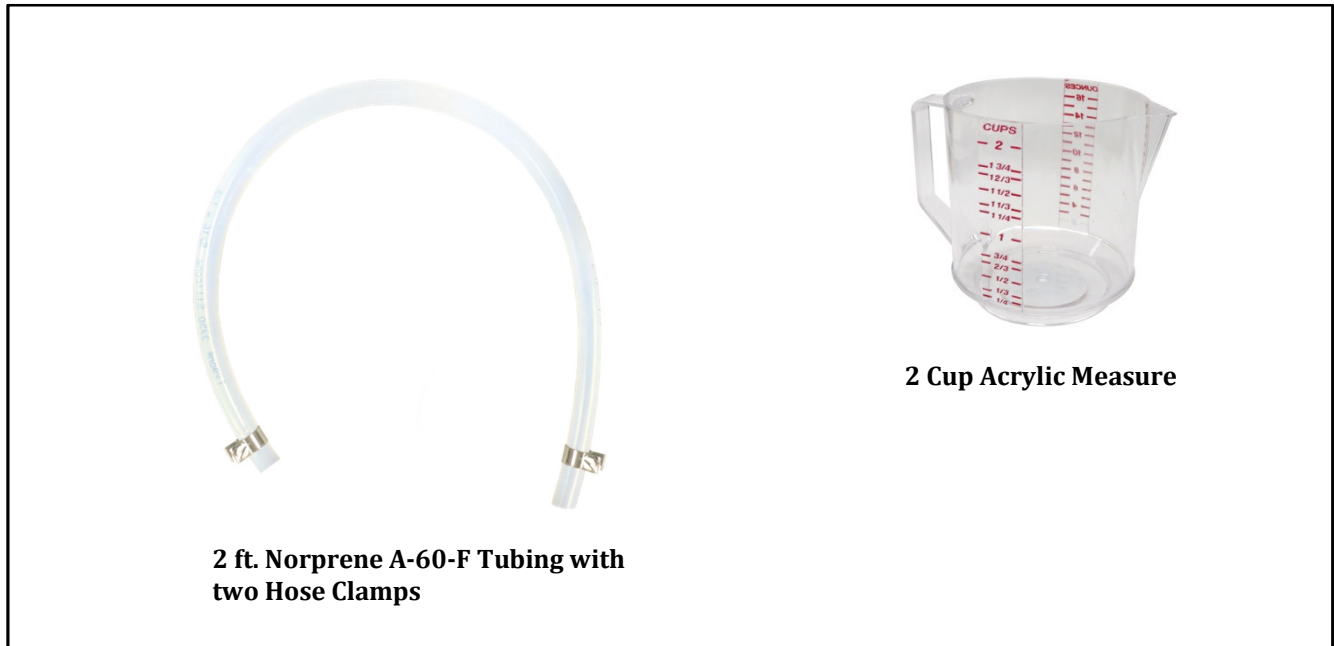

**2 ft. Norprene A-60-F Tubing with
two Hose Clamps**

2 Cup Acrylic Measure

Setup



This unit has been tested at the factory. Remove all packaging and tape prior to operation.



Electrical Requirements

The following power supply must be provided:

2114E, 2114ED: 120 V~, 525 W, 60 Hz.

	 DANGER
	<p>Machine must be properly grounded to prevent electrical shock to personnel. Failure to do so could result in serious injury, or death. DO NOT immerse any part of this equipment in water. DO NOT use excessive water when cleaning. Keep cord and plug off the ground and away from moisture. Always unplug the equipment before cleaning or servicing. Make sure all machine switches are in the OFF position before plugging the equipment into the receptacle.</p> <p>008_051514</p>

This machine is intended to be used with a Gold Medal popcorn popper. The popcorn machine will have a proper power cord to connect to the pump.

A certified electrician must furnish sufficient power for proper machine operation. We recommend the popper powering this unit be on a dedicated and protected circuit. Failure to wire properly will void the warranty and may result in damage to the machine. It is Gold Medal Products Co.'s recommendation that the machine powering this pump be plugged directly into a wall outlet. The use of extension cords is not recommended due to safety concerns, and may cause sacrificed and/or reduced performance.

Before You Plug In Machine

1. Make sure all machine switches on the popper are in the OFF position before plugging the equipment into the popper.
2. Make sure the popcorn machine can accept the grounded plugs (where applicable) on the power supply cord.
3. The wall outlet for the popcorn machine must have the proper polarity. If in doubt, have a competent electrician inspect the outlet and correct if necessary.
4. **DO NOT** use a grounded to un-grounded receptacle adapter on the popper (where applicable).
5. Install the unit in a level position.



Preparing the Pump for Operation

1. Place the Bucket Oil Pump in a pre-melted bucket of oil.

Note: To prevent possibility of damage to the heat element, we recommend pre-melting the oil in the bucket with Gold Medal's Hot Wand (Item No. 2018) before inserting the bucket pump.

2. Attach one end of the Norprene A-60-F Tubing to the Quick Disconnect on the Bucket Pump using the hose clamp provided (see image below).
3. Attach the other end of the Norprene A-60-F Tubing to the metal oil delivery tube (located in popper) using the hose clamp provided.
4. Connect the power cord socket (located under the popper) to the 6 prong plug on the back of the pump.
5. The unit is now ready to be programmed for the oil dispense volume to be delivered to the popper (see Program the EZ Set Timer section).

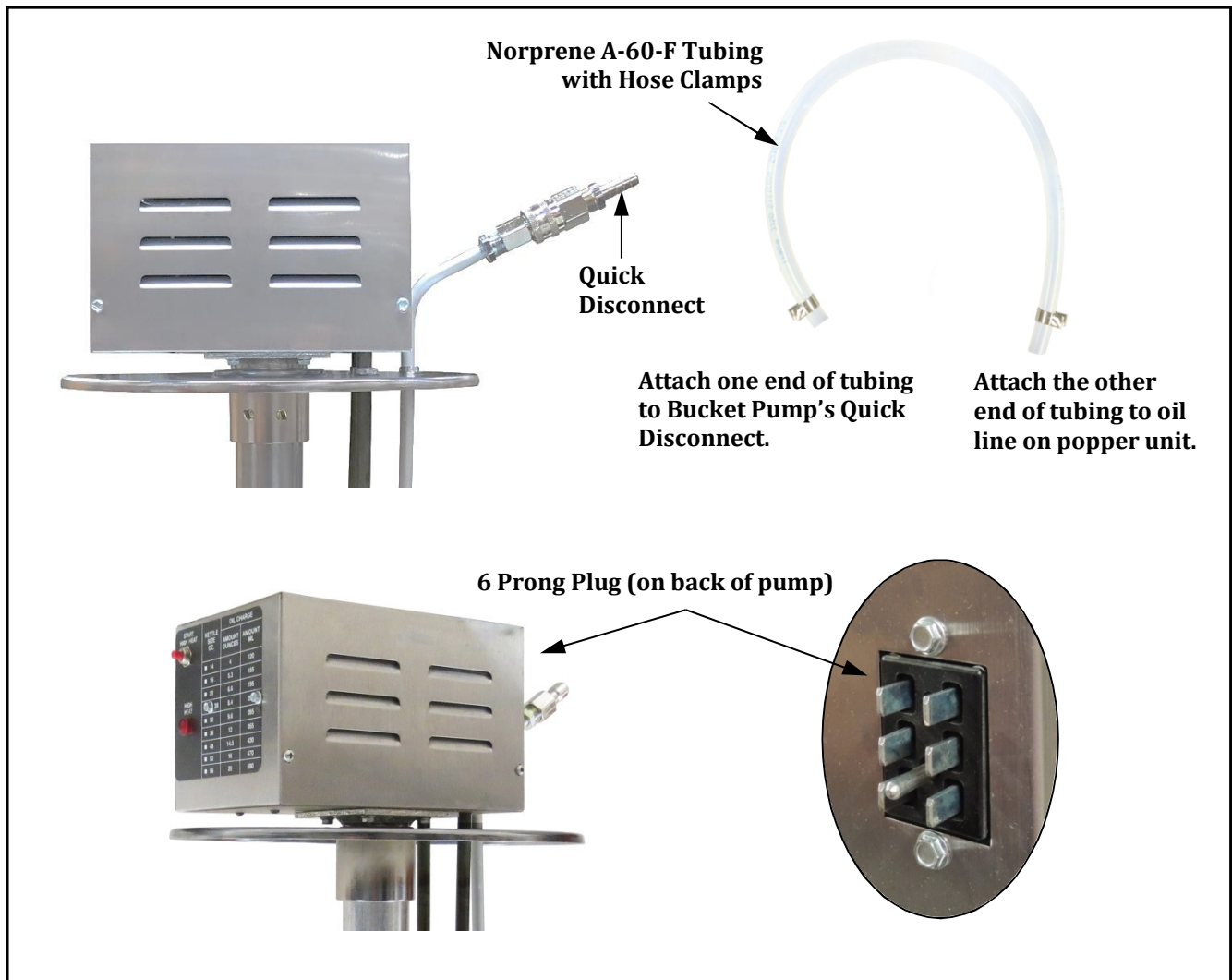



Program the E-Z Set Timer

This unit is equipped with a programmable timer to set the oil amount needed to pop popcorn.

Determine the Oil Charge Ratio

The oil dispense volume is factory set at approx. 4 oz. (120 ml). Use the chart shown to determine the volume of oil needed for the raw corn charge.

Raw Corn Charge		Oil Charge	
ounces	grams	ounces	milliliters
12	340	3.5	103
14	397	4	120
16	454	5.3	155
20	567	6.6	195
28	794	8.4	250
32	907	9.6	285
36	1021	12	355
48	1361	14.5	430
52	1474	16	470

Programming the Timer

To program the timer, follow the steps below using the “Red” Oil Dispense PB Switch and the Oil System Master Switch located on the control panel of the popper.

Note: Take volume measurements from oil delivery tube located in popper above the kettle. Allow kettle to cool completely prior to taking volume measurements.

Priming the Unit:

1. Turn Oil System Master Switch ON.
2. Hold a cup under the oil delivery tube in popper, **PUSH and RELEASE** the RED Oil Dispense Switch to START dispensing oil.
3. As soon as oil flows steady, turn Oil System Master Switch OFF; unit is now primed.
4. Wait 30 seconds to allow oil to drain completely before programming.

Programming the Unit:

5. Hold down RED Oil Dispense Switch and turn Oil System Master Switch ON, **continue to hold RED Oil Dispense Switch for 5 seconds** until the Oil Light on popper starts to blink ON-OFF, then release switch; unit now in program mode.
6. Hold a measuring cup under the oil delivery tube in popper; **PUSH and RELEASE** the RED Oil Dispense PB Switch to START oil flow.
7. When correct amount of oil has been dispensed, **PUSH and RELEASE** Oil Dispense Switch again to STOP oil flow. The RED Oil Dispense Switch may be pushed ON/OFF as many times as needed to finalize (“top off”) the oil amount.
8. Turn Oil System Master Switch OFF, then back ON to **SAVE the setting**. Unit will now dispense the “programmed” amount of oil when the RED Oil Dispense Switch is pushed. The Oil Light on the popper will light continuously when oil pump is dispensing.
9. Wait 30 seconds to allow oil to drain completely before re-checking the oil quantity.

Note: Dual Timer Units - Two oil dispense program settings are available on the control board timer for use with Flexi-Pop (may be used for Salt/Sweet, if unit not equipped with Flexi-Pop). Select one corn amount and program the first timer; then select the other corn amount and program the second timer.



OPERATING INSTRUCTIONS

Controls and Their Functions

This unit is controlled using the Oil System Master Switch (powers the dispenser), and the Oil Dispense Push Button Switch (dispenses oil) located on the control panel of the popper. (Reference the Controls section in the Popper’s Manual.)

HIGH HEAT PUSH BUTTON SWITCH

Pressing the High Heat Push Button Switch activates the heating element for High Heat Cycle. The High Heat Cycle is factory set at 20 minutes (reference High Heat Cycle section on next page).

HIGH HEAT LIGHT

When lit, the red indicator light signals the pump is in High Heat Cycle.

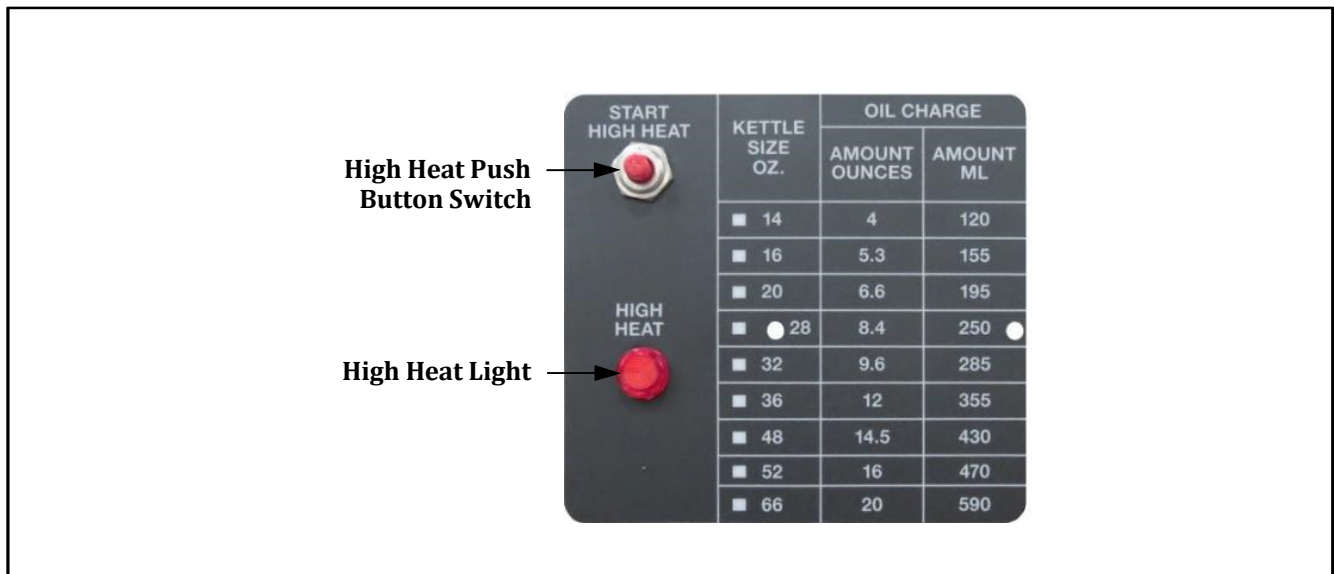

Operating Instructions

With the pump in a melted bucket of oil (see High Heat Cycle section), follow the steps below to turn on the pump:

Note: To prevent the possibility of damage to the heat element, we recommend pre-melting the oil in the bucket with Gold Medal’s Hot Wand (Item No. 2018) before inserting the bucket pump.

1. Turn Oil System Master Switch ON (switch is located on control panel of the popper).
The pump is now ready to dispense the programmed amount of oil. The heat element will maintain the oil in a liquid form. (Reference the Program the EZ Set Timer section to adjust the amount of oil dispensed.)
2. To stop all oil heating, the Oil System Master Switch must be in the OFF position.



High Heat Cycle

The High Heat Cycle is used for a new bucket of oil, or at the beginning of the day, to get oil in the bucket to proper operating consistency. The High Heat Cycle is factory set at 20 minutes.

1. Turn Oil System Master Switch ON (switch is located on control panel of the popper).
2. To start the High Heat Cycle, press the High Heat Push Button Switch located on front of the Bucket Oil Pump.
3. To stop the High Heat Cycle before cycle completes, turn the Oil System Master Switch OFF, wait 5 seconds, then turn the switch back ON.



Note: With the High Heat Cycle off, the heat element will continue to heat the oil in the bucket at about 6% of the high heat output. This will maintain the oil in a liquid form.

4. To stop all oil heating, the Oil System Master Switch must be in the OFF position.



Care and Cleaning

	 DANGER
	<p>Machine must be properly grounded to prevent electrical shock to personnel. DO NOT immerse in water. DO NOT clean appliance with a water jet. Always unplug the equipment before cleaning or servicing.</p> <p style="text-align: right; font-size: small;">025_111616</p>

	 WARNING
	<p>To avoid burns, DO NOT touch heated surfaces. DO NOT place or leave objects in contact with heated surfaces.</p> <p style="text-align: right; font-size: small;">009_092414</p>

Good sanitation practice demands that all food preparation equipment be cleaned regularly (only use non-toxic, food grade cleaners). A clean looking, well-kept machine is one of the best ways of advertising your product.

Follow the directions below to clean and sanitize the unit.

Exterior Surface Cleaning

1. With the machine OFF, unplug the unit and allow it to cool before attempting to clean.
2. The exterior surfaces can be cleaned by wiping oil spills with a dry towel, then wiping with another towel dampened with mild soap and warm water.
3. Wipe stainless steel parts with a clean cloth and cleaner designed for stainless steel, such as Gold Medal Watchdog Stainless Cleaner (Item No. 2088).

DO NOT use oven cleaners or abrasive materials as they will damage parts of machine.

Sanitizing the Tubing and Pump

Items Needed: **(2) Empty Oil Pails** (thoroughly cleaned)

(1) 6-Ft Piece of 5/16" ID Tubing and Clamp (Item No. 102187 and 41163)

Gold Medal Chlor-Tech Sanitizer (Item No. 1109)

Measure Cup (for priming unit)

NOTE: If using a five-gallon bucket, adjust lid collar on pump so unit does not rest on element (loosen thumbscrews on collar, place pump on bucket, then adjust collar position and retighten thumbscrews).

1. With machine off, unplug unit and allow oil pump and popper kettle to cool completely before attempting to clean (always have power disconnected when wiping unit off).
2. Fill a clean, empty pail half-full with hot water and Gold Medal Chlor-Tech Sanitizer (reference instructions on sanitizer container for appropriate amount).



3. Lift bucket pump from oil pail and allow oil to drain from pump, then wipe off any excess oil with a clean cloth.
4. Place pump in pail of solution.
5. Let pump soak for ten minutes, lift pump from solution and wipe down with a clean, solution soaked cloth. Return pump to bucket.
6. Attach the 6-ft piece of tubing to oil dispense tube above popper kettle (see image below).

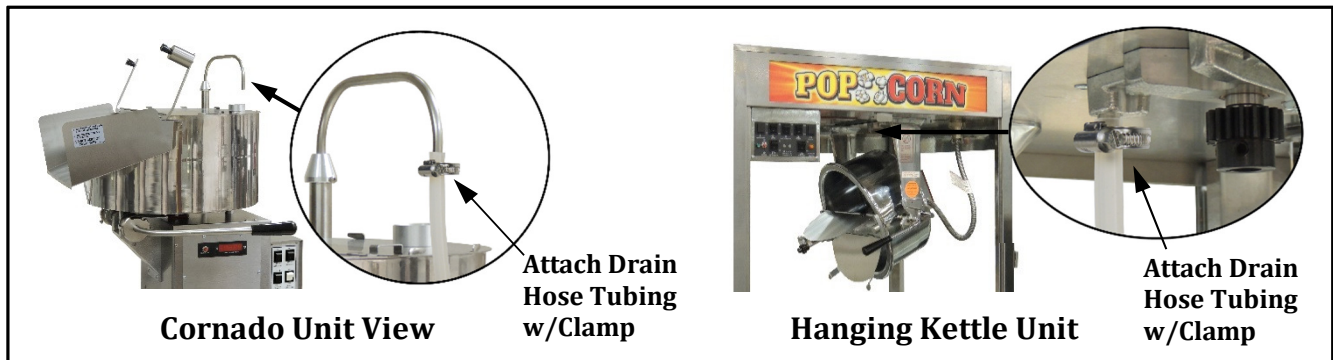

7. Place other end of drain hose in empty pail.
8. Using the “Red” Oil Dispense PB Switch (located on the control panel of the popper), dispense solution until tubes are clean and free of oil.
9. When cleaning is complete, discard the dirty solution, then clean pail and refill with clean, hot water.
10. Lift pump from pail of solution and allow to drain, then place pump in pail of clean, hot water.
11. Switch drain hose to solution pail.
12. Using the “Red” Oil Dispense PB Switch, dispense hot water until tubes are clean and free of sanitizer solution.
13. When cleansing is complete, remove drain hose from oil dispense tube above kettle.
14. Remove pump from water pail and allow it to drain completely of any water, then wipe pump thoroughly dry with a clean cloth before placing back in oil.
15. Place pump in oil pail.
16. Using a measuring cup or medium sized container, the system has to be purged and primed. Use the “Red” Oil Dispense PB Switch to dispense oil into the container until all water has been expelled and tubes are primed with oil. Always discard priming oil dispensed after cleaning.
17. Sanitize cleaning items for next use.







Troubleshooting

Issue	Possible Cause	Solution
Oil Pump Does Not Deliver Oil to Kettle	<p>A. Oil System Master Switch</p> <p>B. Pump is not operating</p> <p>C. Mini Circuit Breaker on popper tripped (if applicable).</p> <p>D. Pump is operating, but oil is not dispensed.</p> <p>E. Timer</p>	<p>A. Check to make sure the Oil System Master Switch is ON (switch is located on the control panel of the popper).</p> <p>B. Check that the pump is plugged into the popper. If the pump is plugged in, but not operating, the pump may need to be replaced. Check with qualified service personnel.</p> <p>C. The mini Circuit Breaker(s) on the popper may be tripped. If reset then trips again, contact qualified service personnel for inspection/repair.</p> <p>D. Check that the oil has not solidified in the lines. Check for air leaks into the oil line. Check to make sure oil supply is not low.</p> <p>E. If oil is only dispensed while the Oil Dispense PB Switch is pushed and held, then timer not programmed correctly. See Program the EZ-Set Timer section of this manual. If wrong oil amount is dispensed, timer needs to be reprogrammed to correct amount.</p>





MAINTENANCE INSTRUCTIONS

	 DANGER
	<p>Machine must be properly grounded to prevent electrical shock to personnel. Failure to do so could result in serious injury, or death. DO NOT immerse any part of this equipment in water. DO NOT use excessive water when cleaning. Keep cord and plug off the ground and away from moisture. Always unplug the equipment before cleaning or servicing. Make sure all machine switches are in the OFF position before plugging the equipment into the receptacle.</p> <p style="text-align: right; font-size: small;">008_051514</p>

	 DANGER
	<p>Improper installation, adjustment, alteration, service, or maintenance can cause property damage, injury, or death. Any alterations to this equipment will void the warranty and may cause a dangerous condition. This appliance is not intended to be operated by means of an external timer or separate remote-control system. NEVER make alterations to this equipment. Read the Installation, Operating, and Maintenance Instructions thoroughly before installing, servicing, or operating this equipment.</p> <p style="text-align: right; font-size: small;">014_020416</p>

	 WARNING
	<p>No user serviceable parts inside. Refer servicing to qualified service personnel.</p> <p style="text-align: right; font-size: small;">011_051514</p>

	 CAUTION
	<p>THE FOLLOWING SECTIONS OF THIS MANUAL ARE INTENDED ONLY FOR QUALIFIED SERVICE PERSONNEL WHO ARE FAMILIAR WITH ELECTRICAL EQUIPMENT. THESE ARE NOT INTENDED FOR THE OPERATOR.</p> <p style="text-align: right; font-size: small;">027_010914</p>



ORDERING SPARE PARTS

1. Identify the needed part by checking it against the photos, illustrations, and/or parts list. (General images may be used in manual for reference only.)
2. Use only approved replacement parts when servicing this unit.
3. When ordering, please include part number, part name, and quantity needed.
4. Please include your model number, serial number, and date of manufacture (located on the machine nameplate/data plate) with your order.
5. Address all parts orders to:

Parts Department
Gold Medal Products Co.
10700 Medallion Drive
Cincinnati, Ohio 45241-4807

Or, place orders by phone or online:

Phone: (800) 543-0862
(513) 769-7676
Fax: (800) 542-1496
(513) 769-8500
E-mail: info@gmpopcorn.com
Web Page: gmpopcorn.com



Pump Exterior View

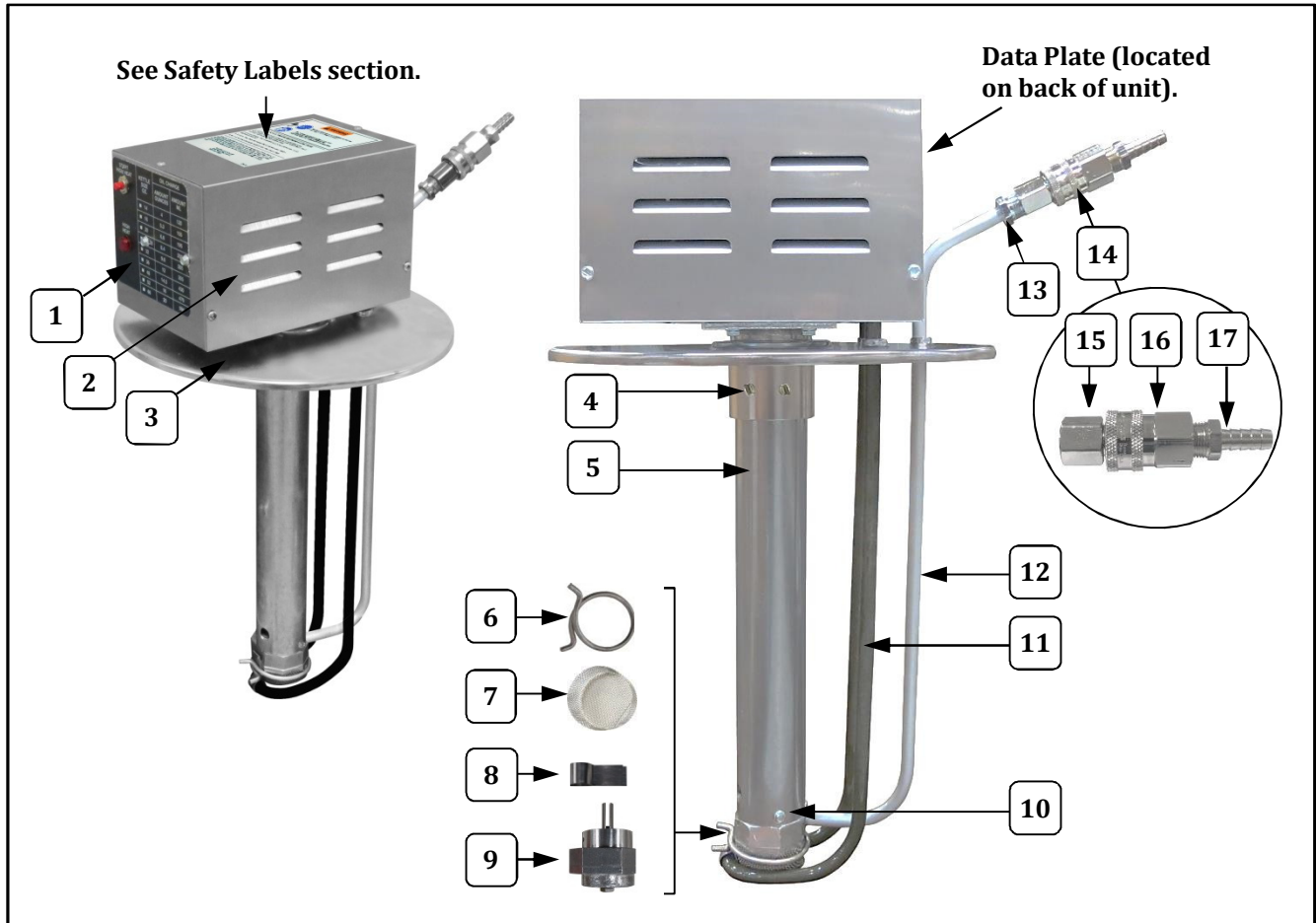

Item	Part Description	Part Number	
		2114E	2114ED
1	HIGH HEAT LABEL	79090	79090
2	JUNCTION BOX COVER	79062	79062
3	BUCKET PUMP LID ASSEMBLY	79030	79030
4	THUMBSCREW 10-24 X 1/4	112000	112000
5	PUMP MOUNTING TUBE	79023	79023
6	FILTER SCREEN CLAMP	79018	79018
7	FILTER SCREEN	79016	79016
8	ELEMENT RETAINER	79017	79017
9	PUMP ASSEMBLY	79001	79001
10	8-32 X 1/4 HX HD WHIZLOCK	42045	42045
11	120 VOLT 500 WATT HEAT ELEMENT	79002	79002
12	OIL DELIVERY TUBE	79015	79015
13	3/8 X 1/8 NPT CP REDUCER	79022	79022
14	QUICK DISCONNECT KIT	79008	79008
15	HANSEN PLUG NP	79251	79251
16	HANSEN SOCKET NP	79250	79250
17	HANSEN HOSE BARB NP	79252	79252



Junction Box Interior – Left Side View

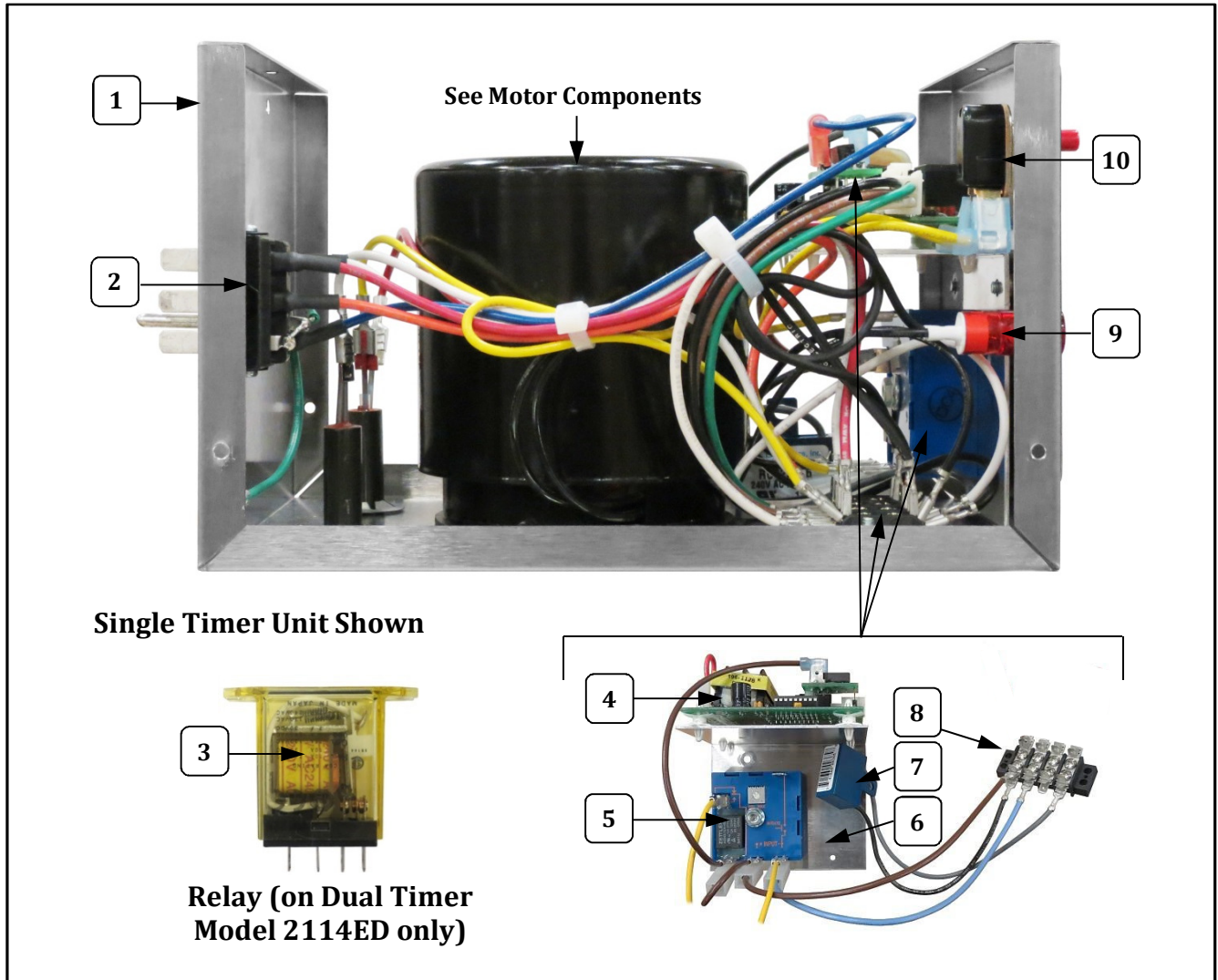

Item	Part Description	Part Number	
		2114E	2114ED
1	BUCKET PUMP JUNCTION BOX	79089	79089
2	CINCH PLUG	79004A	79004A
3	SPDT 120 VAC RELAY		48733
4	TEACH TIMER (Programmable Timer)	48732	48732
5	ADJ 20 MIN SPDT TIMER	55047	55047
6	TIMER BRACKET ASSEMBLY	79135	79135
7	TRANSIENT FILTER	89087	89087
8	TERMINAL BLOCK	45098	45098
9	120 VOLT RED PILOT LIGHT	41033	41033
10	OIL PUMP SWITCH	41031	41031



Motor Components

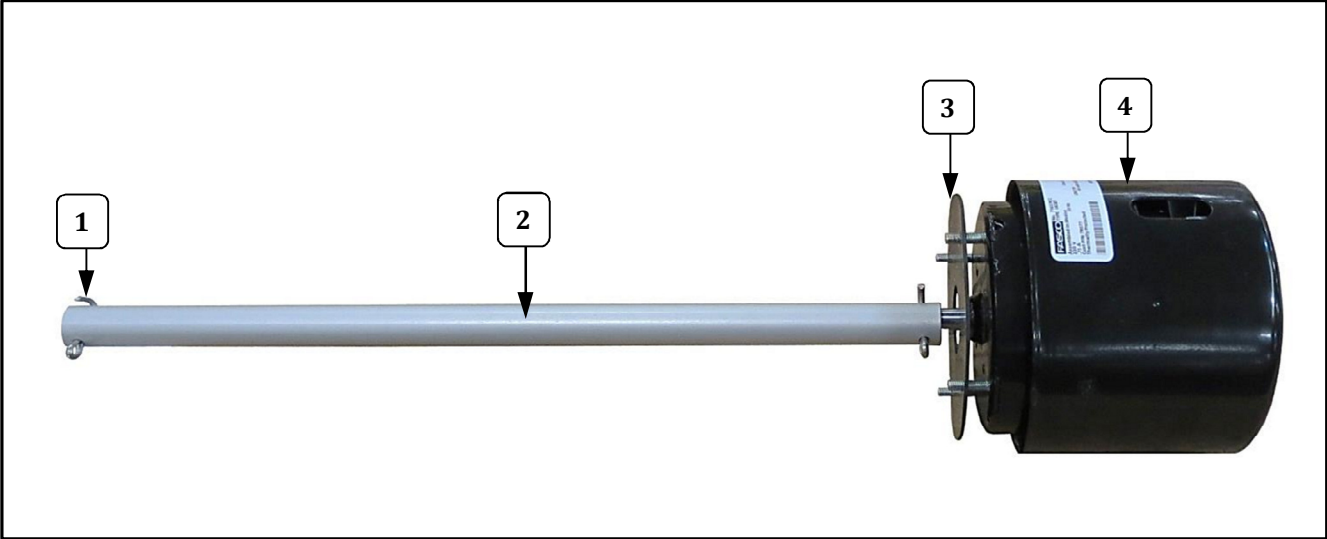

Item	Part Description	Part Number	
		2114E	2114ED
1	1/8 X 1 SS COTTER PIN	86574	86574
2	BUCKET PUMP DRIVE SHAFT	79043	79043
3	PUMP MOTOR GASKET	79005	79005
4	PUMP MOTOR	79006	79006



Safety Labels

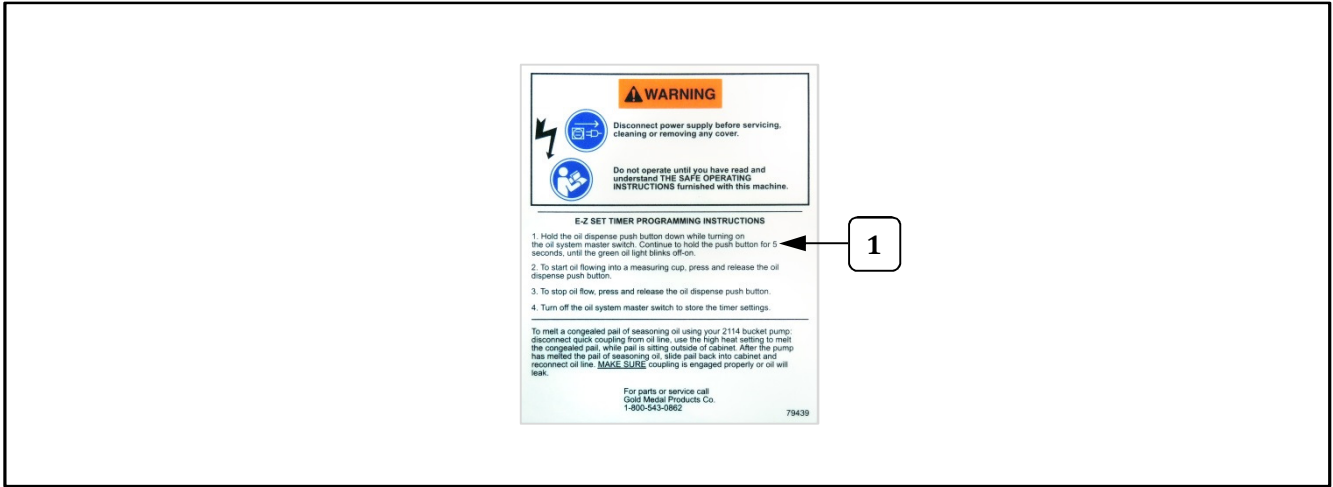

Item	Part Description	Part Number
1	2114 LABEL	79439

Accessories

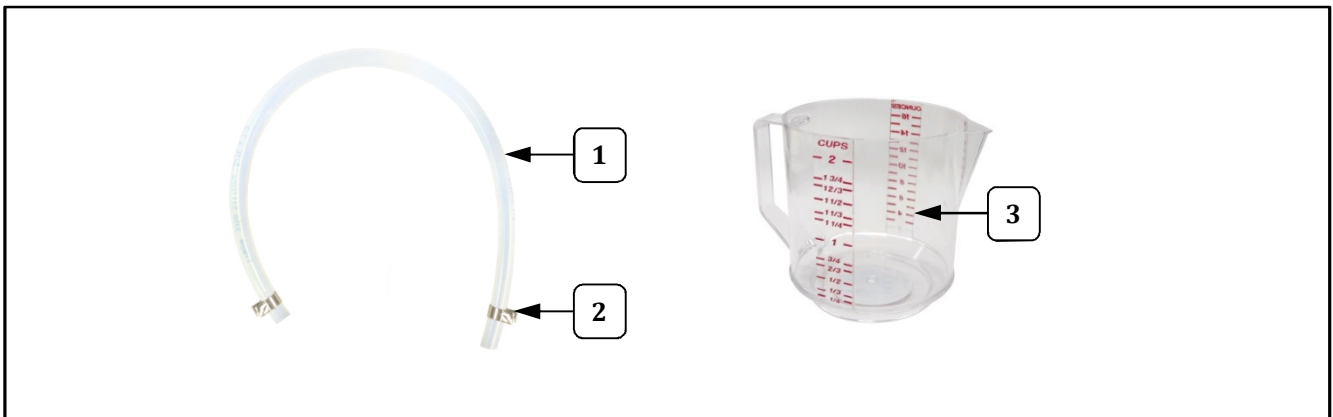

Item	Part Description	Part Number
1	NORPRENE A-60-F TUBING	91703
2	HOSE CLAMP W/SCREW	41163
3	2 CUP ACRYLIC MEASURE	62807



Wiring Diagram

Model No. 2114E

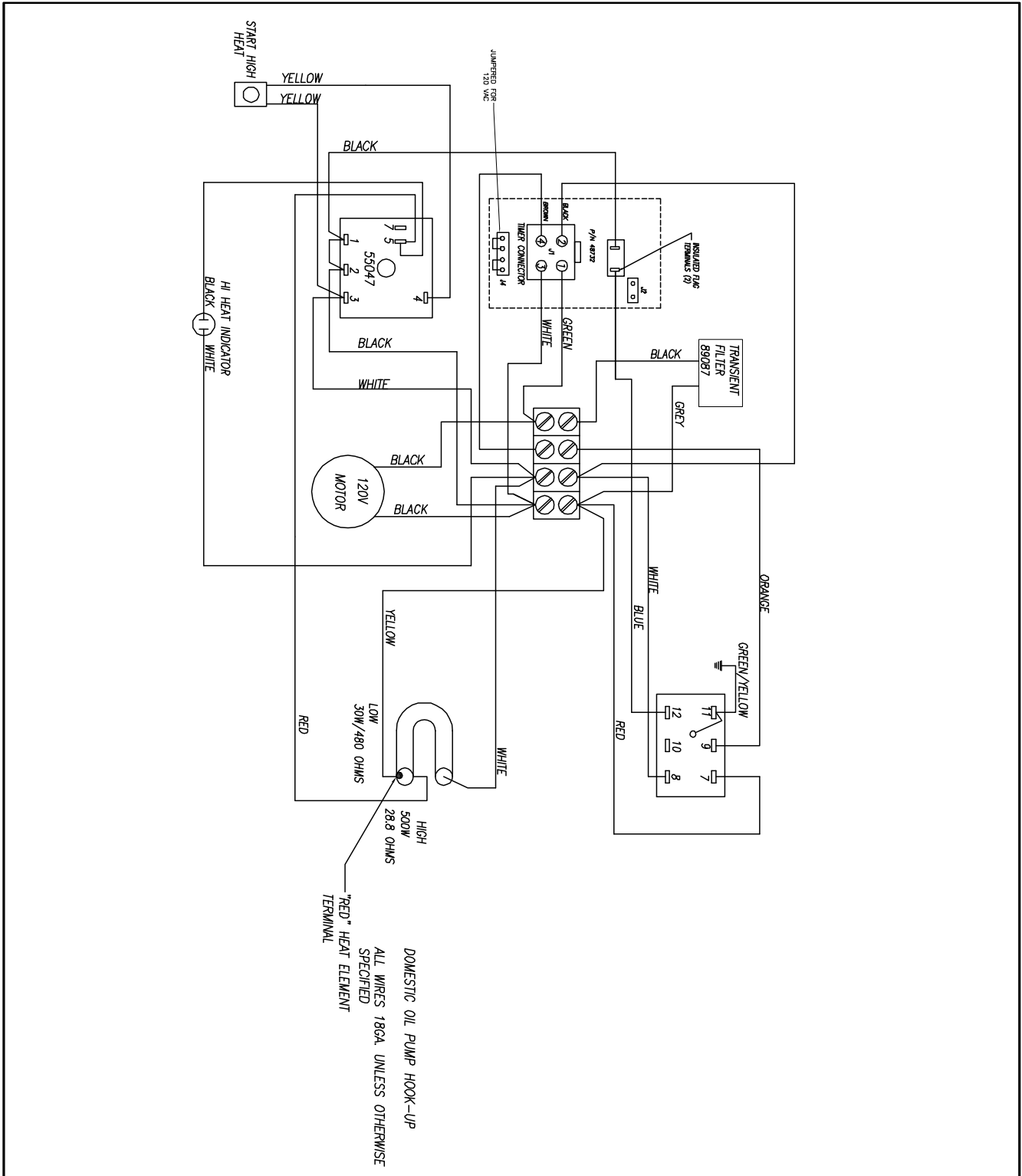



Model No. 2114ED

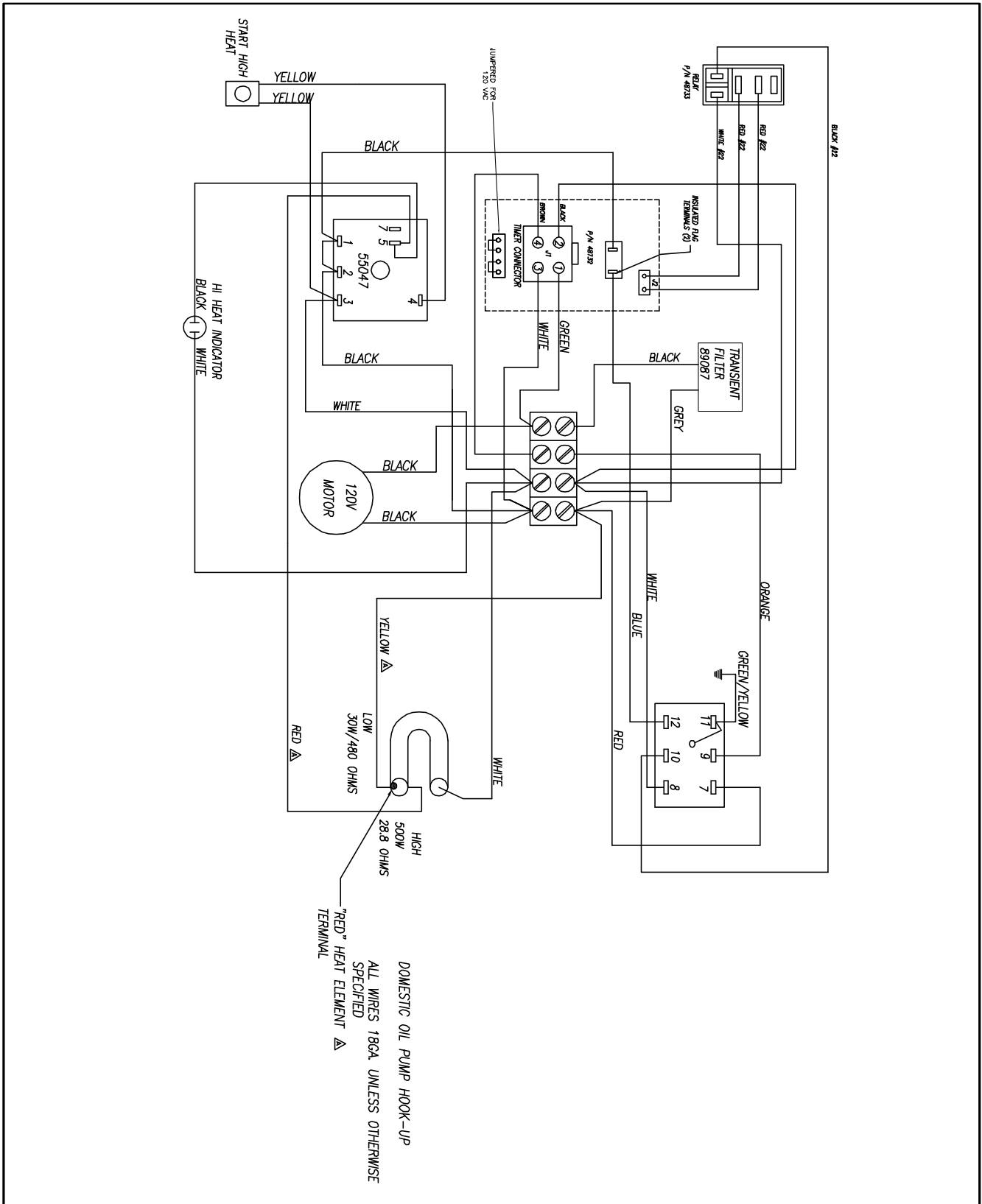



WARRANTY

Gold Medal Products Co. warrants to the original purchaser each item of its manufacture to be free of defects in workmanship and material under normal use and service. Gold Medal Products Co.'s obligation under this warranty is limited solely to repairing or replacing parts, f.o.b. Cincinnati, Ohio, which in its judgment are defective in workmanship or material and which are returned, freight prepaid, to its Cincinnati, Ohio factory or other designated point. Except for "Perishable Parts" on specific machines, the above warranty applies for a period of two (2) years from the date of original sale to the original purchaser of equipment when recommended operating instructions and maintenance procedures have been followed. These are packed with the machine. Parts warranty is two (2) years, labor is six (6) months.

THIS WARRANTY IS IN LIEU OF ALL OTHER WARRANTIES EXPRESSED OR IMPLIED, AND OF ALL OTHER OBLIGATIONS OR LIABILITIES ON OUR PART, INCLUDING THE IMPLIED WARRANTY OF MERCHANTABILITY. THERE ARE NO WARRANTIES WHICH EXTEND BEYOND THE DESCRIPTION ON THE FACE HEREOF. In no event shall Gold Medal Products Co. be liable for special, incidental or consequential damages. No claim under this warranty will be honored if the equipment covered has been misused, neglected, damaged in transit, or has been tampered with or changed in any way. No claim under this warranty shall be honored in the event that components in the unit at the time of the claim were not supplied or approved by Gold Medal Products Co. This warranty is effective only when electrical items have been properly attached to city utility lines only at proper voltages. This warranty is not transferable without the written consent of Gold Medal Products Co.

The term "Original Purchaser" as used in this warranty shall be deemed to mean that person, firm, association, or corporation who was billed by the GOLD MEDAL PRODUCTS CO., or their authorized distributor for the equipment.

THIS WARRANTY HAS NO EFFECT AND IS VOID UNLESS THE ORIGINAL PURCHASER FIRST CALLS GOLD MEDAL PRODUCTS CO. AT 1-800-543-0862 TO DISCUSS WITH OUR SERVICE REPRESENTATIVE THE EQUIPMENT PROBLEM, AND, IF NECESSARY, FOR INSTRUCTIONS CONCERNING THE REPAIR OR REPLACEMENT OF PARTS.

NOTE: This equipment is manufactured and sold for commercial use only.



GOLD MEDAL PRODUCTS CO.

10700 Medallion Drive, Cincinnati, Ohio 45241-4807 USA

gmpopcorn.com

Phone: (800) 543-0862 Fax: (800) 542-1496
(513) 769-7676 (513) 769-8500

© 2016 – The text, descriptions, graphics, layout, and other material in this publication are the exclusive property of Gold Medal Products Co. and shall not be used, copied, reproduced, or published in any fashion, including website display, without its express written consent.