

Astro-Pop Warmer

Part No. 40269
Revised August 2000

Instruction Manual
Models #2004 and #2004SL







 **GOLD MEDAL**®

FUNFOOD EQUIPMENT & SUPPLIES

Cincinnati, OH 45241-4807 USA

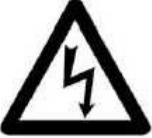
e-mail: goldme19@eos.net • www.gmpopcorn.com

SAFETY PRECAUTIONS

	<p style="text-align: center;">⚠ DANGER</p> <p>Machine must be properly grounded to prevent electrical shock to personnel. Do NOT immerse the equipment in water.</p> <p>Always unplug the equipment before cleaning or servicing.</p>
	<p style="text-align: center;">⚠ WARNING</p> <p>ALWAYS wear safety glasses when servicing this equipment.</p>
	<p style="text-align: center;">⚠ WARNING</p> <p>Any alterations to this equipment will void the warranty and may cause a dangerous situation. NEVER make alterations to the equipment. Make sure all machine switches are in the off position before plugging the equipment into the receptacle.</p>
	<p style="text-align: center;">⚠ CAUTION</p> <p>Do NOT allow direct contact with this equipment and the general public when used in food service locations. Only personnel that are trained and familiar with the equipment should operate the equipment. Carefully read all installation instructions before operation.</p>
	<p style="text-align: center;">⚠ CAUTION</p> <p>This machine is NOT to be operated by minors. Minors are classified as anyone under the age of 18.</p>

NOTE

The information, specifications and illustrations contained in this manual represent the latest data available at time of publication. Right is reserved to make changes as required at the discretion of Gold Medal Products Company without notice.

INTRODUCTION

Your new #2004 Astro-Pop Warmer is shipped completely assembled, ready to operate. After removing the corrugated carton from the machine, check thoroughly for any damage which may have occurred in transit. Claims should be filed immediately with the transportation company.

Remove all cardboard packing and tape from the machine. Wipe all exposed surfaces with a damp cloth to remove fingerprints, smears, etc. which may have occurred during unpacking and handling.



ELECTRICAL REQUIREMENTS

Standard voltage for the Astro-Pop Warmer is 120V, 60 cycle, single phase, A.C. current. The unit should be placed on its own 20 Amp (4 wire) electrical circuit. The switches to control the heater and lights are located at the top on the inside of the cabinet.

CARE AND CLEANING

The aluminum frame of the Warmer is easy to keep clean. Usually a damp cloth will remove all dirt and grease spots. NEVER USE ABRASIVES on the aluminum framework. The glass should always be clean and sparkling. Remember the inside of the glass must be cleaned too. The vertical air ducts, mounted on the inside of the cabinet, disassemble without tools for easy cleaning. Periodically, empty out all the popcorn and remove the shelves and clean the inside of the machine. A damp cloth will usually pick up all the scraps of popcorn that has been spilled. Empty the old maid drawers and wipe clean. Remove the bottom cabinet pans and clean out any stray debris.

MAINTENANCE INSTRUCTIONS

	<p style="text-align: center;">⚠ CAUTION</p> <p>THE FOLLOWING SECTIONS OF THIS MANUAL ARE INTENDED ONLY FOR QUALIFIED SERVICE PERSONNEL WHO ARE FAMILIAR WITH ELECTRICAL EQUIPMENT. THESE ARE NOT INTENDED FOR THE OPERATOR.</p>
	<p style="text-align: center;">⚠ WARNING</p> <p>Adequate eye protection must be used when servicing this equipment to prevent the possibility of injury.</p>
	<p style="text-align: center;">⚠ DANGER</p> <p>Do NOT immerse the kettle, warmer, or any other part of this equipment in water. Unplug your machine before servicing.</p>

ORDERING SPARE PARTS

1. Identify the needed part by checking it against the photos, illustrations, and/or the parts list.
2. When ordering, please include part number, part name, and quantity needed.
3. Please include your model name and machine serial number (located on the machine nameplate) with your order.
4. Address all parts orders to:

Parts Department
Gold Medal Products Co.
10700 Medallion Drive
Cincinnati, Ohio 45241-4807

or, place orders at:

(513) 769-7676
Fax: (513) 769-8500
E-mail: goldme19@eos.net
or Web Page
www.gmpopcorn.com

***See our complete catalog for
more Gold Medal Funfood
Equipment and Supplies***

CABINET ASSEMBLY

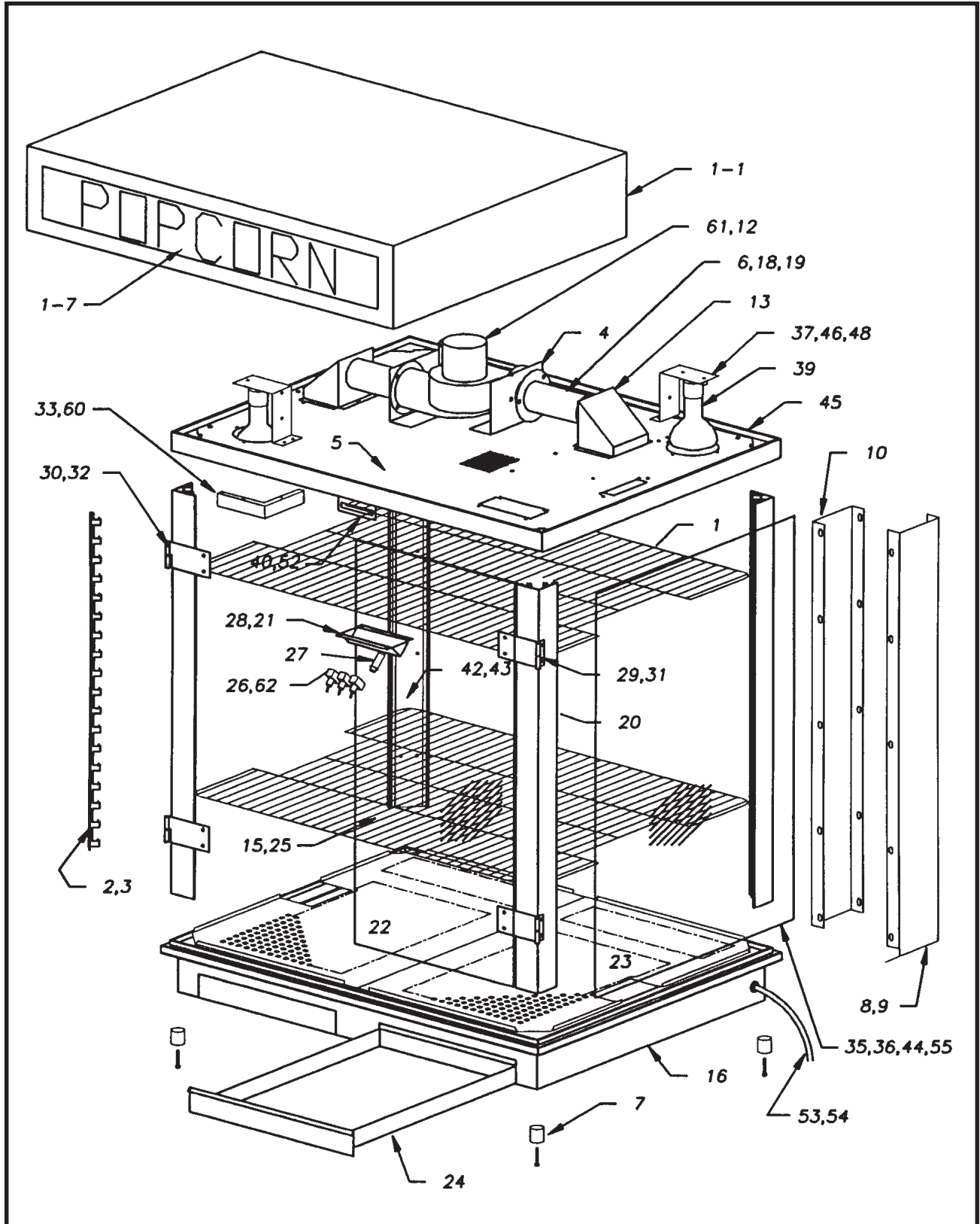

PARTS LIST - CABINET ASSEMBLY

Item No.	Model #2004 Part No.	Model #2004SL Part No.	Description
1	40130	40130	Shelf, Adjustable
2	40143	40143	Shelf Support
3	40142	40142	Shelf Support
4	40145	40145	Blower Bracket
5	40148	40148	Motor Mount Plate
6	40153	40153	Nozzle Heater
7	41282	41282	Rubber Foot
8	40292	40282	Duct Panel
9	40177	40177	Duct Bracket
10	40293	40284	Duct Cover
11	76097	76097	Label, "Unplug to Clean"
12	40184	40184	Intake Cover
13	40185	40185	Exhaust Box
14	n/a	n/a	
15	40352	n/a	Door
16	40193	40193	Bottom Frame Assembly
17	41870	41870	Corner Post, Front
18	40255	40255	Thermostat
19	40270	40270	Thermostat Mount
20	40192	41870	Corner Post
21	40272	40272	Switch Label
22	40297	40297	Corn Pan, L.H.
23	40296	40296	Corn Pan, R.H.
24	40276	40276	Old Maid Pan
25	41013	41013	Knob, Door
26	41016	41016	Single Pole Switch
27	41033	41033	Pilot Light
28	41106	41106	Switch Box
29	41349	n/a	Male Hinge, Right
30	41350	n/a	Male Hinge, Left
31	41351	n/a	Female Hinge, Right
32	41352	n/a	Female Hinge, Left
33	41452	41452	Warning, 75W Max
34	41456	41456	Strain Relief
35	41635PMO	40267	Glass, Front
36	41636PMO	47421	Glass, Side
37	41643	41643	Light Mount Bracket
38	n/a	n/a	
39	41671	41671	Floodlight, 75W
40	41703	41703	Magnet Catch Bracket
41	41712	41712	Molded Receptacle
42	41765	40263	Glass Retainer, Front
43	41766	40264	Glass Retainer, Rear
44	41858	41858	Rigid Channel, 32"

PARTS LIST - CABINET ASSEMBLY (continued)

Item No.	Model #2004 Part No.	Model #2004SL Part No.	Description
45	41946	40169	Top Frame Assembly
46	41956	41956	Light Shield
47	n/a	n/a	
48	47047	47047	Lamp Holder
49	n/a	n/a	
50	n/a	n/a	
51	47282	47282	Bushing, Snap #UB-65
52	47561	47561	Magnetic Catch
53	47580	47580	Lead-In Cord
54	47604	47604	Strain Relief, #SR8P-2
55	47695	47695	Rigid Channel, 23"
56	47701	47701	Acorn Nut, #6-32
57	47702	47702	Acorn Nut, #8-32
58	47771	47771	Screw, #8-32 x 3/8" Hex
59	47772	47772	Screw, #6-32 x 3/8" Flat
60	47799	47799	Light Shield Angle
61	40254	40254	Blower, 50/60 Hz
62	74087	74087	Double Pole Switch
63	74131	74131	Ring Terminal, #10
64	74146	74146	Hex Nut, #8-32
65	74149	74149	Hex Nut, #8-32
66	74150	74150	Washer, #8 Internal Tooth
67	47237	47237	Magnet Strike
68	41526	41526	Dome Spacer

PARTS NOT SHOWN – S/S DOME

Item No.	Model #2004	
	Part No.	Description
1	40198	Complete Dome Assembly
2	40278	Main Wrapper
3	41020	Light Tube Holder
4	41021	Holder with Starter
5	41503	Support Angle
6	41504	Lamp Reflector
7	41506	Popcorn Sign
8	41507	Fluorescent Tube
9	41508	Fluorescent Starter
10	41509	Light Ballast
11	47726	Molded Plug

PARTS NOT SHOWN – SLIDING DOORS

Item No.	Model #2004SL	
	Part No.	Description
12	40289	Left Door Assembly
13	40287	Door Drilling, L.H.
14	40290	Right Door Assembly
15	40288	Door Drilling, R.H.
16	40166	Nylon Bushing
17	40176	Roller
18	40285	Door Stop
19	40286	Door Handle
20	42227	Screw, #8-32 x $\frac{3}{8}$ "
21	40195	Screw, #6-32 x $\frac{3}{4}$ "
22	40273	Top Guide
23	40170	Bottom Track

WIRING DIAGRAM – 2004, 2004SL

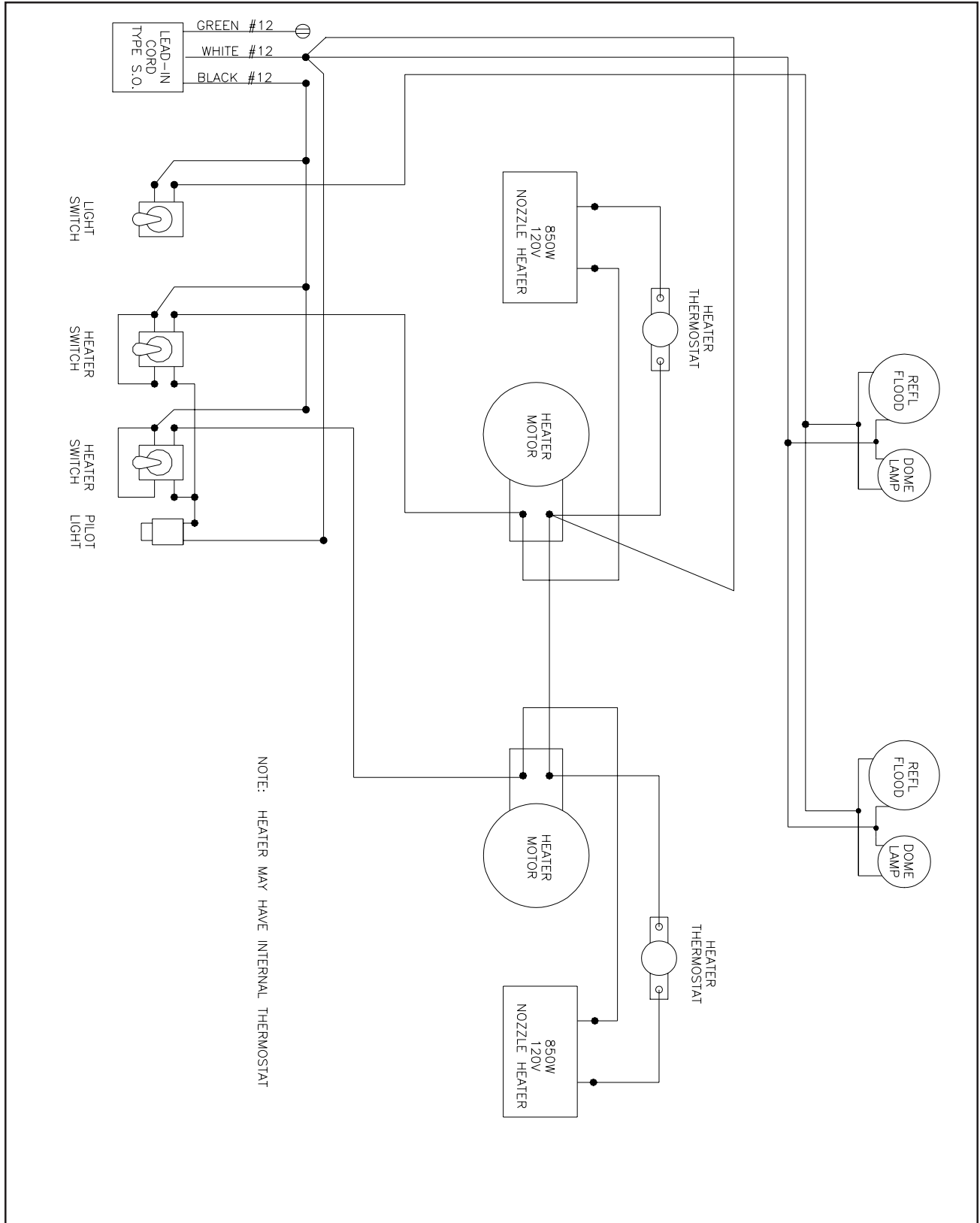

WARRANTY

WE WARRANT to the original purchaser the Gold Medal equipment sold by us to be free from defects in material or workmanship under normal use and service. Our obligation under this warranty shall be limited to the repair or replacement of any defective part for a period of six (6) months from the date of sale to the Original Purchaser with regard to labor and two (2) years with regard to parts and does not cover damage to the equipment caused by accident, alteration, improper use, voltage, abuse, or failure to follow instructions.

THIS WARRANTY IS IN LIEU OF ALL OTHER WARRANTIES EXPRESSED OR IMPLIED, AND OF ALL OTHER OBLIGATIONS OR LIABILITIES ON OUR PART, INCLUDING THE IMPLIED WARRANTY OF MERCHANTABILITY. THERE ARE NO WARRANTIES WHICH EXTEND BEYOND THE DESCRIPTION ON THE FACE HEREOF. We neither assume, nor authorize any other person to assume for us, any other obligation or liability in connection with the sale of said GOLD MEDAL equipment or any part thereof.

The term "Original Purchaser" as used in this warranty shall be deemed to mean that person, firm, association, or corporation who was billed by the GOLD MEDAL PRODUCTS COMPANY, or their authorized distributor, for the equipment.

THIS WARRANTY HAS NO EFFECT AND IS VOID UNLESS THE ORIGINAL PURCHASER FIRST CALLS GOLD MEDAL PRODUCTS COMPANY AT 1-800-428-2676 TO DISCUSS WITH OUR SERVICE REPRESENTATIVE THE EQUIPMENT PROBLEM, AND, IF NECESSARY, FOR INSTRUCTIONS CONCERNING THE REPAIR OR REPLACEMENT OF PARTS.

NOTE: This equipment is manufactured and sold for commercial use only.



GOLD MEDAL PRODUCTS COMPANY
10700 Medallion Drive
Cincinnati, OH 45241-4807 USA