

COP-504W High temp dishwasher - Undercounter



QUICK VIEW	
Dimensions: H x W x D	23 5/8" x 23 5/8" x 32 3/4"
Weight : net/crated (lbs)	132 / 147
Voltage	208-230V/1-3Ph/60Hz
Total Power	6.5 KW
Wash pump (HP)	1

SHORT FORM SPECIFICATION

The unit provided to be a Fagor EVO Concept Plus dishwasher model COP-504W. The Concept Plus dishwashers comes with the following, Effi Wash, Effi Rinse, Eco Fill, Soft Start, Multi-tension and Multi-power systems. Double skin body and door with rock counterbalanced open system.

The unit is constructed with ANSI 304 stainless steel stamped design including wash tank, guides and control panel. IPX4 - Protection against water jets on control panel. Built-in detergent, water pressure and drain pumps. Rinse aid dispenser. 15" clearance for ware.

Each unit comes standard with one (1) flat rack and one (1) peg rack.

Production:

40 racks per hour (factory pre set)
12-40 racks per hour (min-max power output range)

Standard rack size 20" x 20"

Functions and Benefits

Fagor's Concept + range of dishwashers offers a highly efficient and effective washing and rinsing system, becoming the perfect solution for those locations with low pressure water network and high production requirements. Built in durable stainless steel with electromechanical components and simple digital controls for a user-friendly operation.

- **Effi Wash:** Optimized hydraulic system provides a strong mechanical action combined with the optimum clean water in the tank. Balanced power keeps the perfect sanitation temperature during the cycle of the wash.
- **Effi Rinse:** Built-in water pressure pump and air break system assuring the best sanitation result, with a linear 180°F full rinsing cycle. It also works with low incoming water pressure, fitting in installations that do not reach the minimum recommended 15-25 psi.
- **Effi Silent:** Full double skin provides extra insulation on body and door for noise reduction and thermal efficiency.
- **Eco Fill:** New thermostatic water tank filling system that speeds up drastically the start-up time of the machine. Water is heated in the boiler before filling the tank, making the process fast and efficient.
- **Soft Start:** Wash-pump power control that prevents wares from damage at the beginning of the washing cycle while assuring a low noise level on location.
- **Multi Power:** Easily adapt the power level to your needs. Choose the maximum power for the highest production requirements or reduce consumption with a low power set up.
- **Digital Controls:** simple digital control panel with digital temperature display for intuitive and user-friendly operation.

Construction

- New **stainless steel body** structure with **stamped design** (wash tank, rack guides, control panel.), made to resist strong usage.
- AISI-304 Stainless steel double wash / rinsing arms and tray filters.
- Higher clearance : 15 1/4".
- **Rock counterbalanced door.** Double spring and stainless steel hinge system tested to resist the strongest usage. Safe 3 step open system: (1) remove steam, (2) check rack, and (3) remove/ place rack.
- **IPX4** - Stronger protection against water hose cleaning and external humidity.
- **Multi-connection box:** Conveniently located electrical box for easy access that improves maintenance and allows for phase (1/3) and power lever conversion in the field.
- **Built-in detergent, pressure and drain pumps.**

Accessories

- Racks for dishes, glasses and trays
- Cutlery containers and grids
- 6" & 16" high base stands
- Drain tempering valve



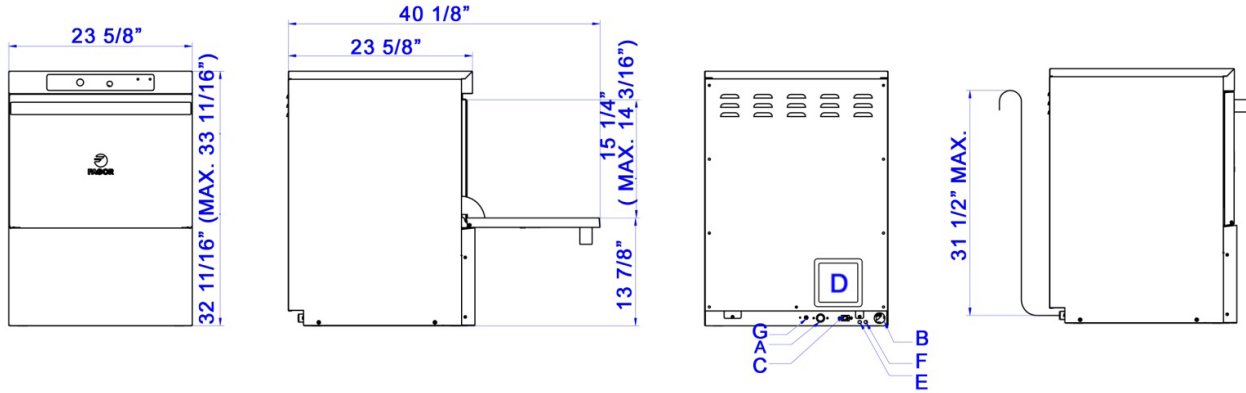

A	B	C	D	E	F	G
Water inlet *	Drain hose **	Power supply cable, strain relief	Terminal box	Rinse aid inlet	Detergent inlet	Equipotential bond ***
<p>* Water inlet 3/4" female hose connector on 5' long flexible hose supplied with machine. Adaptor for 3/4" female garden hose fitting also supplied. 120°-140°F optimum water temperature; 20 -25 psi flow rinse pressure.</p> <p>** Drain 5' long, 1/2" I.D. flexible hose. Maximum 26 3/4" drain height permits indirect connection to drain pump.*** Protection from dangerous potential differences</p>						

SPECIFICATIONS				COP- 504W
Wash Cycles (seconds)				60-90-180
Hot water assurance				●
Electronic control panel and digital display				●
Productivity (*)				
	Racks/hour	Dishes/hour	Glasses/hour	
Factory pre set	40	720	1440	
Max	40	720	1440	
Min	14	252	504	
Standard Rack size (inches)				19 3/4 x 19 3/4
Weight : Net/Crated (lbs)				132 / 147
Dimensions (inches)				
Width				23 5/8
Depth				23 5/8
Height				32 3/4
Useful Loading Height (clearance)				15 1/4
Capacity (gallons)				
Wash Tank				5.28
Boiler				1.85
Water consumption per cycle				0.63

(*) Assumed 18 dishes and 36 glasses per rack

SPECIFICATIONS				COP-504W
Wash pump motor (HP)				1
Power (kW)				
Tank heating element				2.8
Boiler/Booster heating element				1.8 - 2.8 - 3.7- 5.6*
Wash pump(s)				0.6
Pressure pump				0.26
Total power				6.5
Working Temperature (°F)				
Washing				160
Rinsing				180
AMP for 60 Hz				
	Full Power*		Half Power	
Volts	1 Phase	3 Phase	1 Phase	
208	28 Amp	16 Amp	15 Amp	
220	30 Amp	18 Amp	16 Amp	
240	32 Amp	19 Amp	17 Amp	
Water Protection Rating				IPX4
Noise level (dBA)				<65
Detergent & pressure pump				●

* Factory standard

The manufacturer reserves the rights to modify materials and specifications without notice.