



Ovens

ADVANCE PLUS ovens

GAS ADVANCE PLUS OVEN, APG-101

19011070

DIMENSIONS		Article	Packed
Length	mm	898,00	1.100,00
Depth	mm	922,00	1.100,00
Height	mm	1.117,00	1.270,00
Weigth	Kg	169,00	224,00
Volumen	m3	0,92	1,54
ELECTRICITY			
Electric power	KW		1,00
230V -1+N		2x1,5+T - 10 A	
230V - III			
400V - III+N			
PLUMBING - WATER			
Water consumption (lit/h)			30,00
Pressure (Kg/cm2)			0,5 - 8
GAS			
Power	KW		18,00
	Kcal/h		15.480,00
LPG	Consumption (kg/h)		3,28
	Pressure (g/cm2)		37,00
Natural Gas	Consumption (m3/h)		4,24
	Pressure (g/cm2)		18,00
STEAM			
	Not used		
AIR			
	Not used		
LEVEL SOUND			
	(dB)		62,00
Certificate EQNET- CE			
			99BL580

GAS ADVANCE PLUS OVEN, APG-101

High quality, fast cooking :
 - Professional quality and perfect results
 - Easy to use and efficient

Capacity for 10 1/1-GN trays.
 Stainless steel burner with electronic control system with sparking plug ignition.

Frequency modulation for the convection burner.
 "Touch control" screen.

4 cooking methods: Steam, Adjustable Steam (Humidity control during cooking), Regeneration and Convection (up to 300°C).
 Preheating option.

Fagor Easy cooking mode.

Fagor Cooking, range of cooking programmes.

Fagor Multi-Tray System, control cooking by tray.

Delayed programming for: Cooking, Low-temperature cooking and Washing.

Memory function: records the different cooking methods used.

3 Speeds - 2 power ranges.

Cold-Down chamber cooling system.

"Auto-reverse" system to reverse fan rotation.

5 wash programmes.

Multisensor temperature probe.

PC management software: History, recipes. HACCP, manuals...

HACCP cooking data recording system.

Steam generator equipped with limescale detector.

Steam generator automatically empties every 24 hours of cooking.

Semi-automatic limescale removal system.

Error detection system. "Repair service" mode system.

IPX-5 protection.

Retractable shower.

Electrical connection: 230 V - 1+N - 1 KW.

Gas heating capacity: 15,480 Kcal/h. (18 kW).

Dimensions: 896 x 922 x 1,117 mm

Connections points	X	Y	Z	Diameter	Information
ELECTRICITY	732	715	110		Prever Interruptor diferencial
COLD WATER	774	359	110	3/4"	Prever llave de corte en la toma
SOFT COLD WATER	842	359	110	3/4"	Prever llave de corte en la toma
DRAIN	379	292	110	1"	
EXHAUST	593	326	1.117	150	
GAS	815	592	110	R.3/4"G	Prever regulador y llave de corte individual

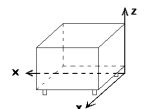

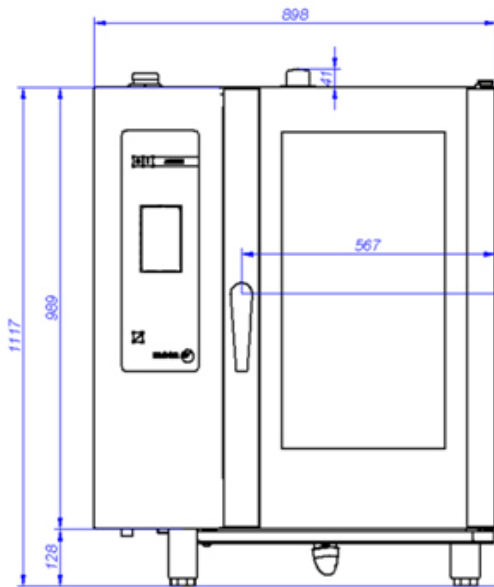

APG-101

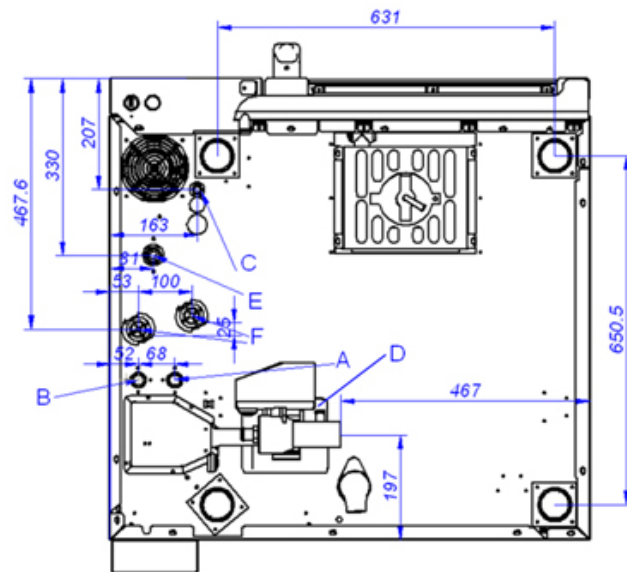

VISTA DE LA BASE DESDE LA PARTE INFERIOR
VIEW FROM THE BOTTOM OF THE MACHINE

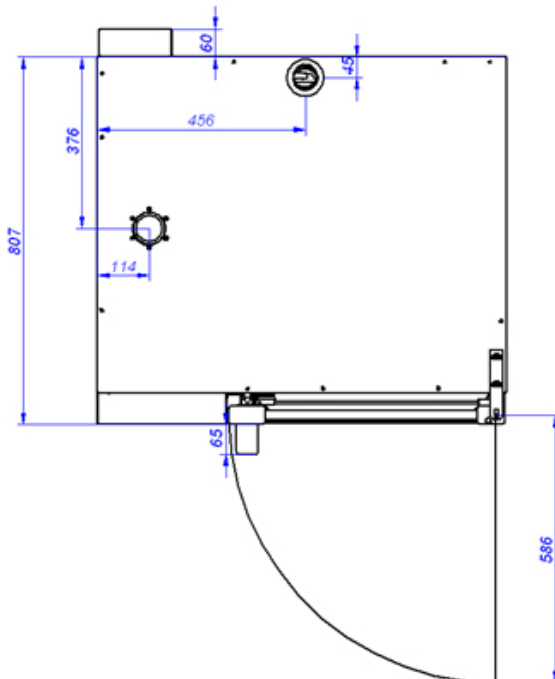

A: Entrada de agua blanda
B: Entrada de agua dura
D: Desagüe

C: Alimentación eléctrica

E: Entrada de gas

F: Entrada de aire

A: Soft water inlet

B: Water inlet

D: Drain

C: Electrical connection

E: Gas inlet

F: Air