



NU-VU®

The Oven/Proofer

For You!



Now YOU can do on-premise baking easily and economically.

The New NU-VU QB-3/9 features our patented V-AIR® system. The heat is distributed evenly throughout the oven cavity thus eliminating the need to turn pans.

The Proofer is pre-set for simplicity of use. Just fill with water and set the temperature.

NU-VU, The Leader in On-Premise Baking, offers everyone a quality oven/proofer. Take our over 30 years of baking experience and put it to use in your establishment.

*Shown with optional racks



Easy To Use

Versatility:

- Muffins
 - Cupcakes
 - Croissants
 - Rolls
 - Breads
- Pies
 - Cakes
 - Brownies
 - Cookies
 - Pastries
- Breadsticks
 - Turnovers
 - Sheetcakes
 - Prepared Foods
 - & More



NU-VU® Food Service Systems • www.nu-vu.com • E-mail: sales@nu-vu.com
5600 13th Street, Menominee, Michigan 49858 • Phone: 906-863-4401 • Fax: 906-863-5889

QB-3/9 Oven/Proofer QB-3/9 CE Oven/Proofer

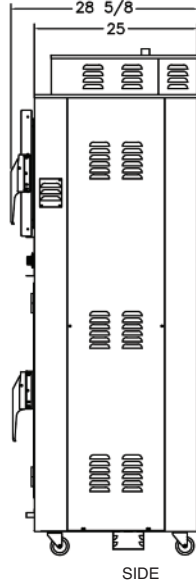
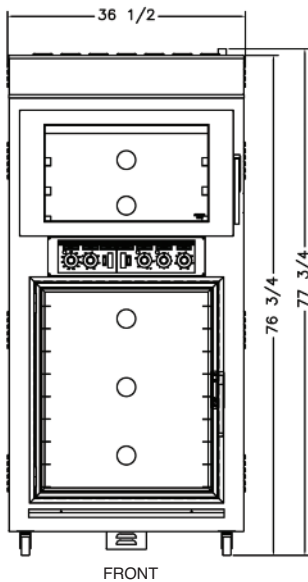
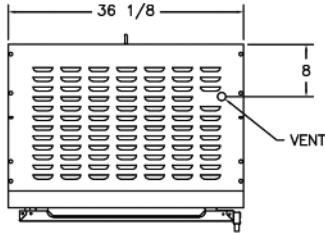

INTERIOR DIMENSIONS:

OVEN - 15"H X 26-1/4"W X 20-1/4"D
PROOFER - 33-1/2"H X 26-1/4"W X 20"

DOOR SWING:

34-3/8"

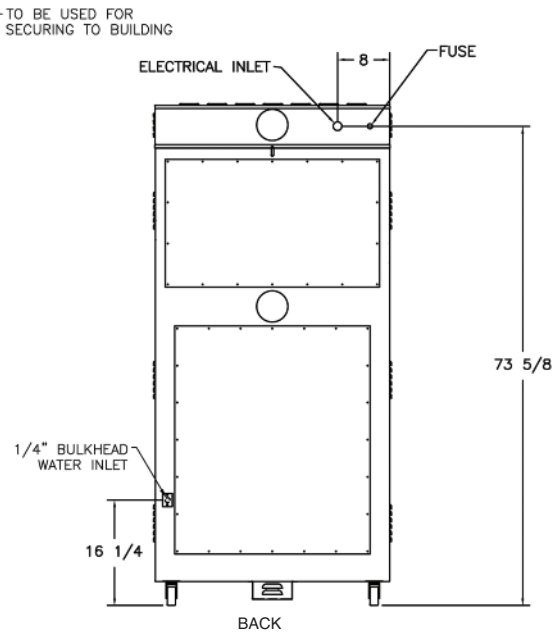

ELECTRICAL:

Single Phase

208V - 28.5 amp - 60hz
240V - 24.5 amp - 60hz
5,135 Watts - 5.135 KW
3 wire system w/ground

Three Phase

208V - 16.5 amp - 60hz
240V - 14.5 amp - 60hz
5,135 Watts - 5.135 KW
4 wire system w/ground

WATER:

A 1/4" waterline is required for units with *AutoMist* option.
A water filtration system should be used to minimize mineral build-up.

LISTINGS:

The QB-3/9 has ETL & NSF listings.



INSTALLATION:

Allow four inches on each side and back of unit for ventilation of oven.

DIMENSIONS:

	Height	Width	Depth
Exterior	77-3/4"	36-1/8"	28-5/8"
Interior			
Oven	15"	26-1/4"	20-1/4"
Proofer	33-1/2"	26-1/4"	20-1/4"

CAPACITY:

Sheet Pans	13"x18"	18"x26"	Spacing
Oven	6"	3	4-1/2"
Proofer	18"	9	3-1/2"

DOOR SWING: Oven - 34-3/8" • Proofer - 29-1/2"

SHIPPING WEIGHT:

570 Pounds, FOB Menominee, MI 49858



NU-VU® Food Service Systems

www.nu-vu.com
5600 13th Street
Menominee, MI 49858

1-800-338-9886 Toll Free
1-906-863-4401 Phone
1-906-863-5889 Fax