

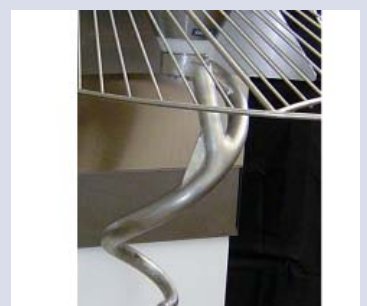

## Spiral Mixer with removable bowl



**ATA100 - ATA150**



### ATA Series spiral mixers

Proper oxygenation, rotational speed, synchronisation of bowl and hook as well as time are crucial for making perfect dough. That is why the award winning Doyon spiral mixer will beat the competition everytime in making the finest quality dough. Great for breads, bagels, pizza and gentle french type dough. Our spiral mixers will significantly reduce your operating time.

# Spiral mixers

## FEATURING

- Simple to use manual or automatic digital control
- 9 personalized programs, enables inexperienced labor to operate the units
- Digital display of mixing time
- 3 to 10 minutes mixing time, depending on type of dough
- Removable stainless steel bowl with a high center that eliminates dough feeder post
- Bowl mounted on casters for greater mobility
- Hydraulic head lifting system
- Automatic bowl locking system
- Keep dough cooler for longer yeast viability and better gluten development
- Increase volume
- Scientifically designed spiral hook for maximum efficiency
- Spiral mixers have 2 speeds for higher efficiency
- 3 powerful independent heavy duty motors; one for the bowl, one for the hook and one for the hydraulic system
- See-through bowl guard with safety interlock. Prevents operation when guard is open
- Safety guard, bowl and mixing tools are stainless steel
- Virtually maintenance free, extremely durable
- Even the smallest batches can be made in our large spiral mixer (see chart)
- Superior torque transmission which eliminates vibration and noise for heavy loads
- Metal-rubber composite gear type belt, non-slipping
- Heavy duty frame with lead-free enamel coating for easy cleaning
- Motor overload protection
- ETL listed
- One year parts and labor limited warranty

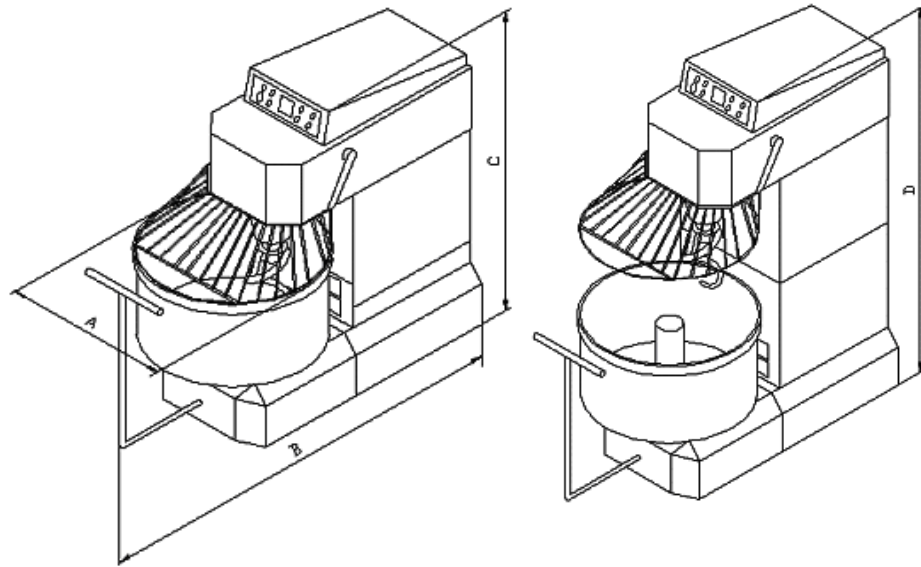

MODEL	Quarts	A	B	C	D	FLOUR CAPACITY		DOUGH CAPACITY (60 % A.R.)		SHIPPING WEIGHT
						min	max	min	max	
ATA100	225	34 1/4" 870 mm	86 5/8" 2200 mm	58 3/4" 1490 mm	78 3/8" 1990 mm	22 lb 10 kg	220 lb 100 kg	35 lb 16 kg	350 lb 160 kg	3120 lb 1416 kg
ATA150	345	38 5/8" 980 mm	90 5/8" 2300 mm	60 5/8" 1540 mm	82 3/8" 2090 mm	22 lb 10 kg	330 lb 150 kg	35 lb 16 kg	520 lb 235 kg	3650 lb 1657 kg

MODEL	HOOK MOTOR	BOWL MOTOR	HYDRAULIC MOTOR	VOLTS	A	PH	Hz	NEMA
ATA100M	10 HP	2 HP	2 HP	208-240	32	3	50/60	15-50P
ATA150M	10 HP	2 HP	2 HP	208-240	32	3	50/60	15-50P

## OPTIONAL

- Integrated water meter
- TAF100 removable stainless steel bowl for ATA100
- TAF150 removable stainless steel bowl for ATA150



Your local distributor: / Votre distributeur:

1255, rue Principale  
Linière, Beauce, Québec, Canada G0M 1J0

Telephone.: 418-685-3431  
Canada: 1-800-463-1636  
E-mail : doyon@doyon.qc.ca

Fax: 418-685-3948  
U.S.: 1-800-463-4273  
Internet : <http://www.doyon.qc.ca>