



**MODEL E ENERGY SAVER**

LOW WATER MACHINES

**USES ONLY**  
**1.01**  
**Gallons Of Water**  
**Per Cycle!**



**MODEL E**  
**AVAILABLE IN STRAIGHT**  
**AND CORNER MODEL**



**OPTIONAL 3 DOOR**  
**MODEL AVAILABLE**  
**FOR STRAIGHT AND**  
**CORNER OPERATION**



**MODEL E EXT**  
**WITH 20-1/2" DOOR**  
**OPENING**  
**AVAILABLE IN STRAIGHT**  
**AND CORNER MODEL**

**FEATURES AND FACTS:**

- **Energy Star Qualified.**
- 40 racks / 160 covers per hour.
- Economical to operate. **Uses only 1.01 gallons of water per cycle.**
- All stainless steel construction assures long life and years of trouble free operation.
- Unique spray arm system features upper and lower stainless steel wash arms with reinforced end caps.
- Top mounted controls include built-in chemical pumps and delimiting system for dealing with scale.
- Auto start/stop makes operation safe and easy.
- New integrated scrap tray prevents food soil from entering drain system.
- Airgap fill system.

**CONVERTIBLE CORNER TO STRAIGHT AND STRAIGHT TO CORNER.**

**Available Options**

- Sanitizer Alarm
- Alternative cycle times
- Pull Pins
- Stainless Steel Scrap Trap Up Grade
- The "TEMP-SURE" requires a seperate 208-240v 3 phase 40 amp power supply
- 3 Doors open
- Extended (Tall) version





**MODEL E ENERGY SAVER**  
**LOW WATER**  
**MACHINES**

**WARNING:** Plumbing connections must be made by a qualified service company who will comply with all available Federal, State, and Local Health, Plumbing and Safety codes.

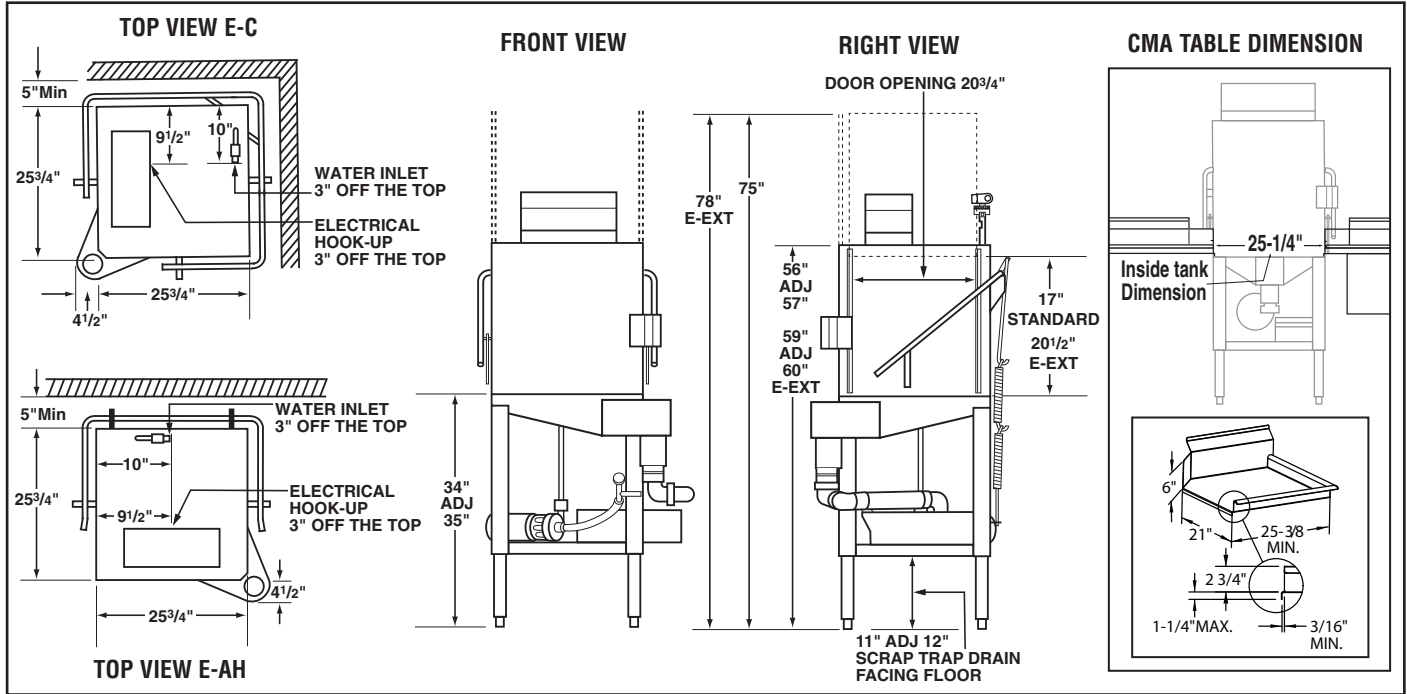

**Specifications:**

MODEL E/E-3/E-EXT	USA	METRIC	USA	METRIC
<b>OPERATING CAPACITY</b>			<b>WASH PUMP MOTORS HP</b>	1
RACKS PER HOUR (NSF RATED)	40	40	<b>DIMENSIONS</b>	
<b>OPERATING CYCLE</b>			DEPTH	25-3/4" (65.4cm)
WASH TIME-SEC	45	45	WIDTH (OUTSIDE DIMENSION)	25-3/4" (65.4cm)
RINSE TIME-SEC	30	30	HEIGHT	56"-57" (142.2cm-144.8cm)
DWELL TIME-SEC	15	15	E-EXT 59"-60"	(150cm-152cm)
TOTAL CYCLE TIME	90	90	STANDARD TABLE HEIGHT	34" (86cm)
PUMP CAPACITY	52 GPM	(197 LPM)	MAXIMUM CLEARANCE FOR DISHES	17" (43cm)
<b>OPERATING TEMPERATURE</b>			E-EXT 20-1/2"	(52cm)
REQUIRED	120°F	(49°C)	<b>STANDARD DISHRACK DIMENSIONS</b>	19-3/4"X19-3/4" (50X50cm)
RECOMMENDED	140°F	(60°C)	<b>ELECTRICAL RATING</b>	
<b>WATER CONSUMPTION</b>			<b>VOLTS</b>	115
PER RACK	1.01 GAL.	(13.79 L)	<b>AMPS</b>	16
PER HOUR	37 GPH	(139 LPH)	<b>SHIPPING WEIGHT APPROXIMATE</b>	
<b>WATER REQUIREMENTS</b>			218#	(98.7kg)
WATER INLET	1/2"	(1.27cm)	E-EXT L 260#	(117.8kg)
DRAIN-I.P.S.	2"	(5.1cm)		

**Summary Specifications: Model E/E-3/E-EXT**

CMA Energy Miser model E/E-3/E-EXT(Extended 20-1/2" door opening) low temperature, chemical sanitizing commercial dishwashers meet ETL, UL, and CUL sanitation and construction standards WITHOUT the use of BOOSTER or TANK HEATERS. The model E/E-3/E-EXT is constructed entirely of stainless steel. Each unit automatically washes, rinses and sanitizes utensils in standard 19-3/4"x19-3/4" racks. Units come with standard upper and lower stainless steel wash arms. **Note: This machine does not have built-in heaters, therefore produces no steam.**

