

# Champion®

The Dishwashing Machine Specialists

Project \_\_\_\_\_  
Item No. \_\_\_\_\_  
Quantity \_\_\_\_\_

**PRO SERIES RACK CONVEYOR**

## STANDARD FEATURES

- NEW **Ventless Heat Recovery** Technology
  - **No** Type II exhaust **hood** required
  - **Saves** up to **13kW** during operation
  - **Less than 70° conditioned air** back into the dish room
- Perpetual rack advance system, with intuitive jam alert, and drive protection
  - Proportional rinse, delivering unmatched total ware coverage, utilizing digital pattern cloning, stainless steel nozzles
  - 209 racks per hour
  - 100 GPH with energy sentinel (idle pump shut-off)
  - Prodigy series HMI display, intuitive condition alerts, with user friendly cleaning and operation visual guidance, multi-lingual, touch control
  - Proactive maintenance interface, self-diagnostics, problem recognition, with repair recommendation, from HMI touch screen
  - Programmable machine dwell with automatic rack alignment into the optimal wash zone
  - Leak-proof ball valve drains
  - Single-piece hood design
  - Single-piece stainless steel upper and lower wash arm manifolds
  - 20" standard vertical clearance which accommodates 18" x 26" sheet pans
  - Full 180° opening leak proof insulated hinged access doors
  - Stainless steel heavy gauge construction including base, legs and feet
  - Enclosure panels (front and sides)
  - Factory Authorized Start-up
  - **Made in America**



## PRO SERIES

**66 PRO VHR Electric**  
Ventless Heat Recovery  
High Temperature Rack Conveyor  
Dishwashing Machine



44-PRO-VHR shown; 66-PRO-VHR will have a 22" pre-wash.

*Photo is for general visual representation only. Please refer to specifications for the latest detailed product information.*



## SPECIFIER STATEMENT

Specified unit will be Champion Model 66 PRO VHR Series Ventless Heat Recovery high temperature rack conveyor dishwashing machine. Features top mounted Prodigy HMI user interface controls with proactive maintenance software, proportional rinse, using only 100 GPH, built-in 21 kW booster, progressive anti-jam drive system, energy sentinel (idle pump shut-off), 209 racks per hour, single-piece hood design, single-piece stainless steel upper & lower wash arms manifolds, full 180° opening leak proof insulated hinged access doors.

1 year parts and labor warranty.

Champion Industries, Inc.  
3765 Champion Blvd., Winston-Salem, NC 27105  
Tel: 336/661-1556 Fax: 336/661-1979  
[www.championindustries.com](http://www.championindustries.com)

# PRO SERIES

## 66 PRO VHR Electric

Ventless Heat Recovery  
High Temperature Rack Conveyor  
Dishwashing Machine

# Champion®

The Dishwashing Machine Specialists

## MODEL 66 PRO

Shipping weight crated: **600 lbs.**

Dimensions shown in inches [mm]

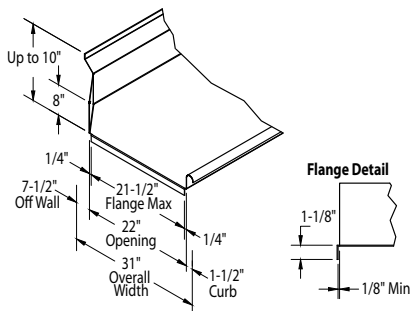
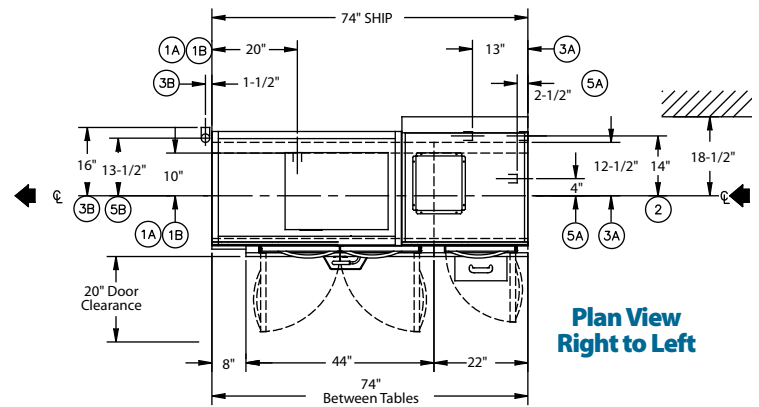
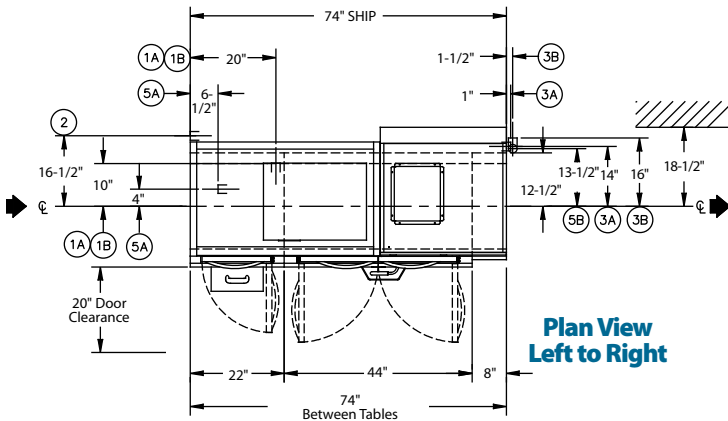
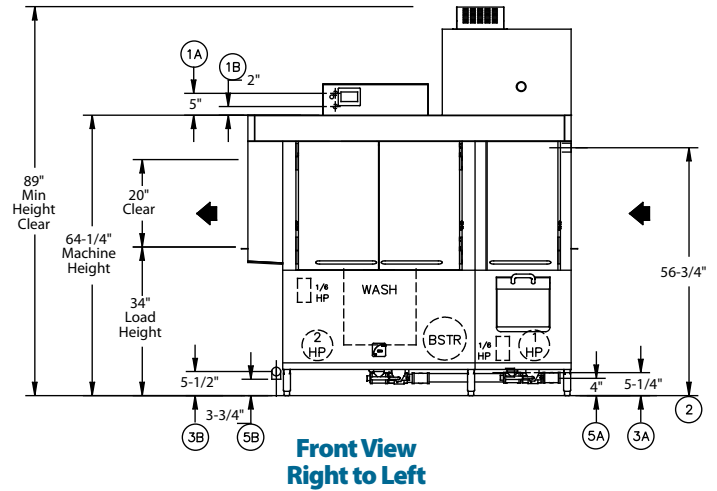
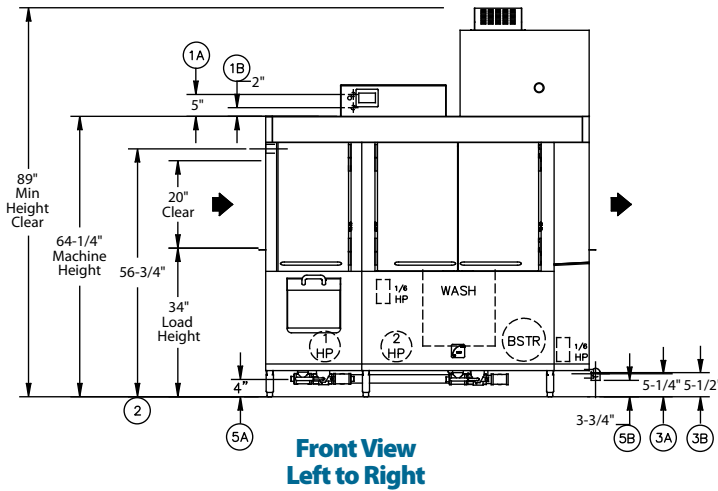

### Suggested Table Construction

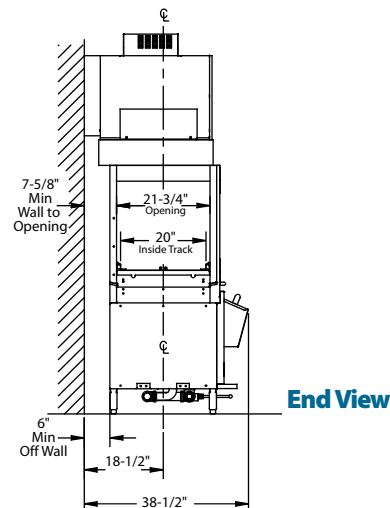

Due to an ongoing value analysis program at Champion, specifications contained in this catalog are subject to change without notice.

Champion Industries, Inc., 3765 Champion Blvd., Winston-Salem, NC 27105 • 336/661-1556 • Fax: 336/661-1979 • www.championindustries.com

# PRO SERIES

## 66 PRO VHR Electric

Ventless Heat Recovery  
High Temperature Rack Conveyor  
Dishwashing Machine

# Champion®

The Dishwashing Machine Specialists

Utilities	
<b>1</b>	<b>Electrical Connection</b> <b>A</b> Machine electrical connection (to include tank heat) <b>B</b> Booster electrical connection
<b>2</b>	<b>Hot Water</b> Tank fill 1/2" NPT
<b>4</b>	<b>Cold Water</b> Booster connection 1/2" NPT
<b>5</b>	<b>Drain</b> Connection 1 1/2" NPT

**Warning:** Plumbing and electrical connections should be made by qualified personnel who will observe all the applicable plumbing, sanitary, safety codes and the National Electrical Code.

**Note:** Water Hammer Arrestor (meeting ASSE-1010 standard or equivalent) to be supplied (by others) in common water supply line at service connection.

**Plumbing Notes:** Because of the variation in house-supplied steam and water pressures, steam and water pressure regulating valves (PRVs) may be needed. (Water PRV is standard on machines with booster.) The PRVs can either be purchased from Champion or obtained locally.

**Venting Notes:** The Ventless feature is subject to local codes for ventilation requirements.

66 PRO VHR Electric Heat (1A)			
Electrical Specifications	Rated Amps	Minimum Supply Circuit Ampacity	Maximum Overcurrent Protective Device
208/60/3	81	110	110
240/60/3	74	100	100
480/60/3	37	50	50
575/60/3	30	40	40

66 PRO Electric 21 kW Booster (1B)			
Electrical Specifications	Rated Amps	Minimum Supply Circuit Ampacity	Maximum Overcurrent Protective Device
208/60/3	58	75	75
240/60/3	51	65	65
480/60/3	25	35	35
575/60/3	21	30	30

## SPECIFICATIONS

### Capacity

Racks per hr. (NSF rated)	209
Wash tank (US gal.)	21
Conveyor speed (ft/min.)	5.8

### Motor Horsepower

Drive	1/6
Wash	2
Pre-Wash	1

### Water Consumption

US Gal. per hr. (max. use)	100
US Gal. per rack	0.48

### Heating

Tank Heat, electric (kW)	15
Electric booster (built-in) (kW supplied for 40°F rise)	12
Electric booster (built-in) (kW supplied for 70°F rise)	21

*Booster heaters completely inter plumbed, controls are interwired*

Latent Heat Load	5789
Sensible Heat Load	7789

### Standard 20" x 20" rack complement

Peg	2
Flat	1

Due to an ongoing value analysis program at Champion, specifications contained in this catalog are subject to change without notice.

Champion Industries, Inc., 3765 Champion Blvd., Winston-Salem, NC 27105 • 336/661-1556 • Fax: 336/661-1979 • www.championindustries.com

# PRO SERIES

PRO SERIES RACK CONVEYOR

## 66 PRO VHR Electric

Ventless Heat Recovery  
High Temperature Rack Conveyor  
Dishwashing Machine

### OPTIONS & ACCESSORIES

- Single point electrical connection machine and booster (Contact Factory)
- 2 Hp prewash motor
- 24" Sideload
- 30" Sideload (accepts sheet pans)
- Extended pawl bar (extended drive unit) for use with load tabling
- Racks: peg or flat racks (specify type)
- Table limit switch, unmounted (recommended on all rack conveyor installations)
- Water pressure regulating valve (unmounted) (standard with booster)
- Water hammer kit
- Drain tempering kit
- Model CCT 180 (180° Corner Conveyor Table)
- Model CCT 90 (90° Corner Conveyor Table)
- Model RCT 64 or RCT 84 Roller Conveyor Table (See factory for custom length)
- Splash shields
- ION scale prevention device
- Cold water thermostat for pre-wash

# Champion<sup>®</sup>

The Dishwashing Machine Specialists



#### NEW CCT 90

90° Corner Conveyor Table (shown)

#### NEW CCT 180

180° Corner Conveyor Table  
also available



**Cantilever  
Sideloader**  
(No hood)



#### Model RCT 64 or RCT 84

Roller  
Conveyor Table

Champion Industries, Inc.,  
3765 Champion Blvd., NC 27105  
336/661-1556 • Fax: 336/661-1979  
ChampionIndustries.com

8/17

an Ali Group Company



The Spirit of Excellence