

# AMERISINK

## GRANITE COMPOSITE

## GRANITE COMPOSITE SINK

## AS602

### Features

- 33"(L) x 20.5"(W) x 9.5"(H)
- Undermount
- Up to 85% Quartzite, up to 15% Acrylic
- Highly resistant to scratches, stains, chips, and heat
- Non-porous, food approval, hygienic, UV resistant
- Acrylic Natural Sound Dampener, 100% recyclable
- Easy maintenance
- All the way color through
- Limited lifetime warranty



### Colors

- Alpina (white), Colorado (beige), Onyx (black metallic)

### Product Diagram

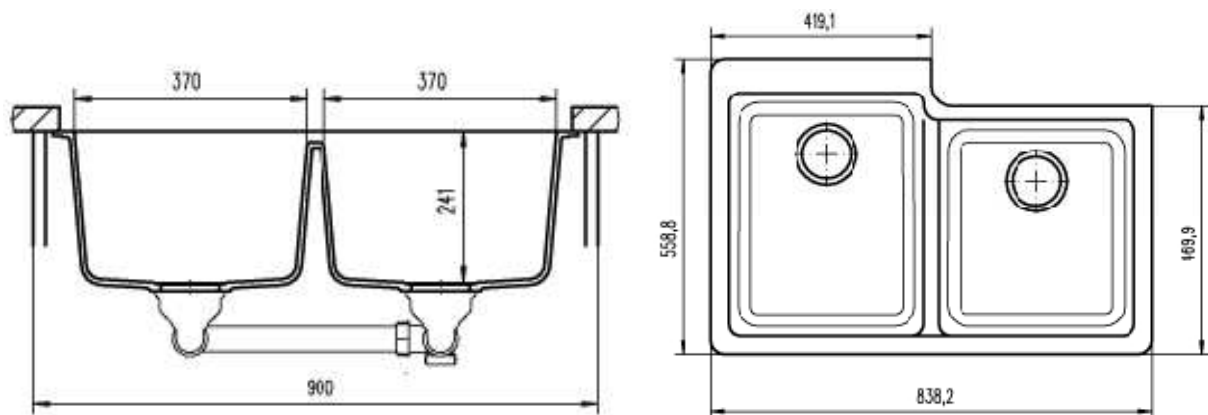

WWW.AMERISINK.COM

877-500-7465

West Coast Warehouse: 510-667-9998 ▲ East Coast Warehouse: 404-691-5088