

AMERICAN RANGE

QUALITY LINE OF COOKING EQUIPMENT

ARKB HEAVY DUTY KEBOB BROILERS

STANDARD FEATURES

- Individually controlled Stainless Steel 30,000 BTU/hr. burners placed every 6", providing maximum output, flexibility and low maintenance.
- Heavy duty radiant bars for optimum heat distribution.
- Radiant bars individually removable for easy cleaning.
- Heavy gauge supports are spaced to hold skewers.
- 14 ga. all welded heavy duty reinforced fire box.
- Stainless Steel polished front and trim for easy cleaning, with fully-insulated double-layered all-welded steel chassis.
- Full length removable crumb tray for easy cleaning.
- Optional 4" legs or equipment stand available.
- One year limited warranty, parts and labor.



ARKB-36

Model ARKB-36-R
Shown with optional rotisserie and stand.

The American Range Heavy Duty Kebob Broiler is engineered to provide reliable performance for many years. This broiler allows juices from the meat to drip down onto the radiants, resulting in searing flames and smoke flavor.

The innovative design features heavy gauge steel support bars specially spaced to allow support of the "shish" skewers. Individually controlled 30,000 BTU/hr. burners located every six inches provide complete coverage of a large cooking area. Front control valves flexibility to operate chosen burners as needed thus saving energy. All our quality counter appliances come standard with a Stainless Steel exterior and the best warranty in the business.

Look to American Range for innovation, reliable performance, quality and attention to your equipment needs and delivery, now and in the future.

ARKB HEAVY DUTY KEBOB BROILERS

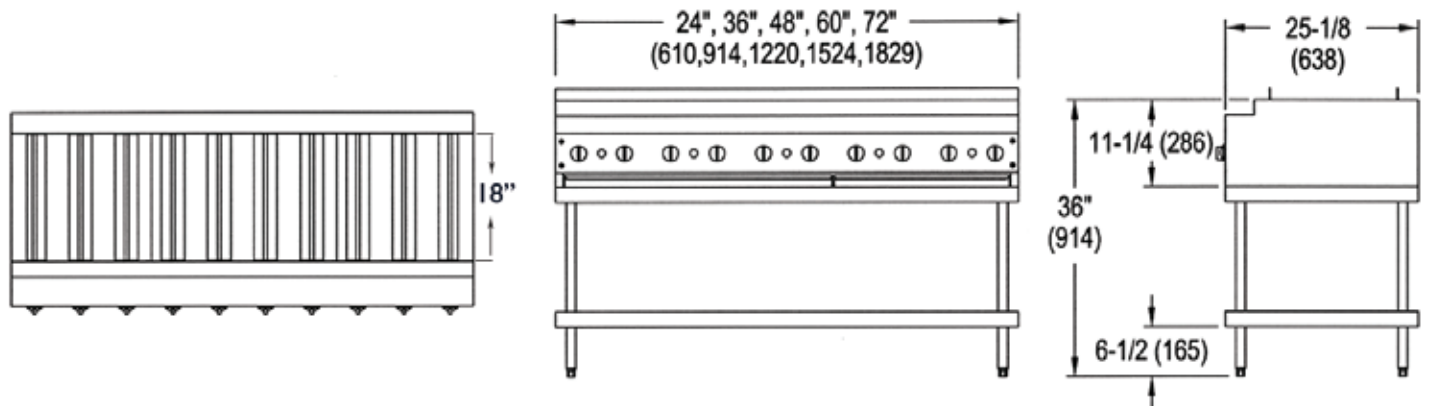

Model	Width	Depth	Height	Burners	Total BTU	KW	Shipping Weight	Lbs.	Kg.
ARKB-24	24"	25-1/8"	11-1/4"	4	120,000	35		200	90
ARKB-30	30"	25-1/8"	11-1/4"	5	150,000	44		230	104
ARKB-36	36"	25-1/8"	11-1/4"	6	180,000	53		320	145
ARKB-48	48"	25-1/8"	11-1/4"	8	240,000	70		360	163
ARKB-60	60"	25-1/8"	11-1/4"	10	300,000	88		400	182
ARKB-72	72"	25-1/8"	11-1/4"	12	360,000	106		440	200
ARKB-84	84"	25-1/8"	11-1/4"	14	420,000	123		480	218

STANDARD FEATURES

- Individually controlled Stainless Steel straight burners.
- 30,000 BTU/hr. spaced every 6" (152).
- Optimum heat distribution with heavy duty angled radiants, removable for easy cleaning.
- Angled radiants control flare-up while still imparting the char-broiled flavor.
- Heavy duty cast iron top grates, 3" (76) x 22" (559) reversible. with grease runners to direct run off to the grease trough.
- Full width grease pan, removable for easy cleaning.
- 14 gal. all welded Heavy Duty reinforced fire box.
- One year limited warranty, parts and labor.

OPTIONAL FEATURES

- 4" (102) counter legs.
- Rotisserie option add '-R', 2 amp, 120V 60z 1Ø
- Stainless Steel skewers

GAS SUPPLY: 3/4" NPT Gas inlet. Manifold pressure is 5.0"W.C. for natural gas or 10.0"W.C. for propane gas. Specify type of gas and altitude if over 2000 feet.

CLEARANCES: For use only on non-combustible floors. Legs or casters are required, or 2" (51) overhang is required when curb mounted. Clearance from non-combustible walls is 0". When unit is placed next to combustible walls, clearances must exceed 12" (305) on sides, and 4" (102) from rear. Radiant broilers for non-combustible locations only.

American Range is a quality manufacturer of commercial cooking equipment. Because of continuing product improvements these specifications are subject to change without prior notice.



13592 Desmond St. Pacoima CA 91331
 T. 818.897.0808 F. 818.897.1670
 Toll Free: 888.753.9898
www.americanrange.com